



COMMUNITY BOARD NO. 1

435 GRAHAM AVENUE – BROOKLYN, NY 11211

PHONE: (718) 389-0009

FAX: (718) 389-0098

Email: bk01@cb.nyc.gov

Website: www.nyc.gov/brooklyn1

HON. ERIC L. ADAMS
BROOKLYN BOROUGH PRESIDENT



SIMON WEISER
FIRST VICE-CHAIRMAN

DEL TEAGUE
SECOND VICE-CHAIRPERSON

STEPHEN J. WEIDBERG
THIRD VICE-CHAIRMAN

MARIA VIERA
FINANCIAL SECRETARY

SONIA IGLESIAS
RECORDING SECRETARY

PHILIP A. CAPONEGRO
MEMBER-AT-LARGE

DEALICE FULLER
CHAIRPERSON

GERALD A. ESPOSITO
DISTRICT MANAGER

HON. STEPHEN T. LEVIN
COUNCILMEMBER, 33rd CD

HON. ANTONIO REYNOSO
COUNCILMEMBER, 34th CD

COMBINED PUBLIC HEARING AND BOARD MEETING 211 AINSLIE STREET JUNE 11, 2019

Note to all speakers: All those who wish to speak during Public Session must sign and submit their speaker's form at 5:45 PM, and no later than 6:15PM.

Elections for the Executive Committee and the Attendance Committee will take place promptly at 8:00 PM.

PUBLIC HEARING

ROLL CALL

Chairperson Ms. Dealice Fuller called for the meeting to come to order and requested District Manager Mr. Gerald A. Esposito to call the roll. He informed the Chairperson that there were 28 members present. A sufficient number to call the public hearing to order.

APPROVAL OF THE AGENDA

Chairperson Fuller asked all to review the agenda. Mr. Solano made a motion to approve the agenda as written. Ms. Teague seconded the motion. The motion was unanimously carried.

1. UNENCLOSED SIDEWALK CAFÉ: UNENCLOSED SIDEWALK CAFÉ, Jemanya Corp., 57 S. 5th Street, Brooklyn, NY 11249-5106, Application # 1331625-DCA, 9 tables, 18 chairs. (renewal). Mr. Janis, from SWA Architecture, represented the application and provided a presentation. They were applying for a renewal. There was no change in the application. No questions were raised at this time. The item was referred to the committee.
2. UNENCLOSED SIDEWALK CAFÉ: UNENCLOSED SIDEWALK CAFÉ, Martha's 263 Bedford Ave LLC, dba Martha's Country Bakery, 263 Bedford Ave. Brooklyn, NY 11211. Application # 2047685 DCA, 14 tables and 28 chairs (renewal). A presentation was not made. No comments were received. The item was referred to the committee.

3. **UNENCLOSED SIDEWALK CAFÉ: UNENCLOSED SIDEWALK CAFÉ**, Madre Hospitality Inc., 214 Franklin Street, Brooklyn, NY 11222, Application # 5680-2019-ASWC, 4 tables, 16 chairs (renewal). There was no presentation at this time. No comments were received. The item was referred to the committee.

4. **PRESENTATION: SECRET LOFT LLC, DBA SECRET LOFT, 90 SCOTT AVENUE, BROOKLYN, N.Y. 11237** (Randolph St. & Scott Ave.) – Applicant to present on their application for a new liquor license. The establishment states capacity of over 350 persons. (located in the East Williamsburg Industrial Zone) – Representative: Dr. Alex Neuhausen, Owner/Manager). A presentation was made by the owner, Dr. Neuhausen. He was joined with Billie Wilson. He noted that the facility is a performing arts venue, at 90 Scott Avenue. He related that they have been operating a small performing arts venue in Greenwich Village. They have been operating for two years there specializing in comedy and other events. He related that he has been here in Williamsburg in since 2012. He related that the space on Scott Avenue (by the Jefferson "L" train stop. It was a warehouse. He related that they put on community oriented events (i.e. open mike, comedy, poetry, etc.). He noted that they also do charity events. They are proposing to use the space (that looks like an aircraft hangar). It will take about 6-9 months to do the conversion of the space. They will have a large open space that could be divided into three spaces. They want to be open until 4AM. He welcomed anyone to come and talk with them. They will be here at the meeting. He displayed a map of the area. They were around the corner from the Vietnamese restaurant. They will also do circus shows for all ages (including children). They will have three public open houses. They will have art shows. They will have writing workshops with Brooklyn poets and other community groups. He said that they have done community outreach, including the NYPD and FDNY. They have reached out to the business community, including Evergreen. They will be hiring security and have a comprehensive security plan. Mr. Burrows noted that the SLA Review Committee asks that applicants with spaces for over 250 people come before the full board so that the members can hear what is going on. His concern is that with this space other people have come before with an intent of the opening the space venue. With this application, there were concerns about using the large space after the shows. Across the street is 99 Scott Avenue (a venue that was not approved by the board). He was concerned about the area (heavy traffic, need for street lighting, trucks, and poor roadway conditions) and being the night life center for Brooklyn. It has to be looked at how to make it safe and responsible out there. This application will be coming back to the committee. They are trying to figure out what they are going to do once the performance is over. Mr. Solano raised concern about the area being an IBZ. What happens if the venue doesn't work as a proposed family oriented event space? Dr. Neuhausen disagreed that the area was a hellhole. DOT is working everyday on the potholes. Ms. Nieves raised concerns about safety measures, lighting and security.

5. **PRESENTATION: BSA APPLICATION: (BSA ITEM #2019-95-BZ) 19 MASPETH AVENUE, AKA 220 CONSELYEA STREET, BLOCK 2893 LOTS 1 & 15** – Application for a variance to facilitate the construction of new six story approximately 17,364 sf building with a conforming commercial use on the ground floor and residential uses on the upper floors, contrary to the use regulations of the underlying C8-2 district. (Rep./Slater & Beckerman PC). It was noted that this was to be voted on). Ms. Teague said that in her land use committee report that they came to present on the application but they were not ready to do a presentation. They were trying to get BSA to hold off the hearing until after the summer, but that hasn't been able to happen. A presentation will be made and the Land Use Committee will caucus for making a recommendation so that the board could vote on it this evening.

Mr. Ben Stark, from Slater & Beckerman PC, represented the application. The owner of the property, Capscar III LLC, is the applicant to the BSA for a variance to permit development at 19 Maspeth Avenue. This application seeks a modification to permit residential uses within a new six story and cellar building (proposed building) in a C8-2 zoning district at 19 Maspeth Avenue. The proposed building will contain approximately 17,384 square feet of floor area, and will include a conforming commercial use on the ground floor and non-conforming residential uses on the upper stories. Due to unique conditions that exist on the subject property, including its irregular triangular shape and size, there are practical difficulties and unnecessary hardships in realizing a reasonable economic return while strictly conforming to the use provisions of the Zoning Resolution. Approval of the requested variance would allow the applicant to realize a reasonable rate of return while developing the property with a multi-purpose building.

- The property consists of a small triangular lot, which occupies an entire block bounded by Conselyea Street, Maspeth Avenue, and Woodpoint Road.
- The property is located within a C8-2 Commercial District.
- The property consists of two tax lots which have been in single ownership since 2010. On July 14, 2017 the two tax lots were established as a single zoning lot.
- The property has a lot area of approximately 2,966.80 sq. ft. and is currently used as an unimproved parking lot. Historically the subject property was used for residential and commercial purposes.
- The proposed building is to keep with the character of the surrounding area.
- The proposed building will have a total of 15 residential apartments, with three apartments on each of the second through sixth floor.
- No yards or open spaces are proposed because of the zoning lot's small size and three frontages. The rise of the building will be to 59 ft, 22 inches.
- The renderings will show more and how it fits in with character.

Mr. Stark introduced the site's owner, Paul Scarola, he is one of the owners of New York Heating Corp., on Humboldt Street. Mr. Scarola noted that he was in business for over 30 years in CB#1. They employ over 30 people. They often do their recruiting and training locally. They provide service for many local properties. Mr. Stark spoke about the heating company and related that they have a supply house on Ainslie Street. They sell to community. He related that they actually take care of the boilers in this building. In the new building they will have retail on the first floor and supply jobs for the community. They are looking to recruit new men and women to work for the company and train them in boilers. They have a training facility on Humboldt Street. The board members discussed the proposed project with the applicant's representative and property owners. It was noted that the surrounding area has a lot of residential uses and the proposed building would be conforming. Mr. Stark pointed out the R6 property. The shape of the building is a wedge and rises without a setback. Questions were raised about affordable housing and the size of the apartments (i.e. for families). Ms. Kuonen related that some of the apartments could have more bedrooms. Ms. Chesler asked about the site and any archeological discoveries? They have been discussing this with Landmarks. Mr. Stark spoke about the purchase of the building. They did not buy the building with the intention of developing a residential building. It was noted that if they withdrew the application now, they would lose their spot at BSA. The owner wanted to develop the property but couldn't do it feasibly as-of-right. He then wanted to look at developing it in a way that would make sense and benefit the community. They can relook at the numbers. The board could do a conditional vote. It can be a two

way street. Ms. Rachlin raised concern about wages, Mr. Needleman asked if they plan to hire women. Ms. Teague stated that the Land Use Committee will caucus later on the item in order to present a recommendation to the full board. The committee adjourned to the adjacent room to discuss the land use item.

6. **PRESENTATION: INFORMATIONAL UPDATE REGARDING THE GREENPOINT MUSEUM ECOLOGICAL SHORELINE** – by Janice Lauletta-Weinmann, Lauren Micir (AECOM), Susan Bemis.

A presentation was made by Ms. Lauletta-Weinmann and colleagues from AECOM. Ms. Micir related that she and her colleague were landscape architects with AECOM. They have been working with Janice for a few years to put this project together. Tonight they will present an update on the project. The presentation included PowerPoint graphics. She discussed the key elements and strategy. The location was outlined. The presentation is attached. They thanked all for their support. It was related that Motiva Enterprises donated the land at the Bushwick Inlet Park to the Greenpoint Monitor Museum. The museum received a GCEF (Greenpoint Community Environmental Fund) grant to develop an ecological design for shoreline restoration and stabilization at the future site of the Museum building, raise the land for flood protection, and provide community access. The engineering firm AECOM prepared conceptual drawings pro bono to assist in securing this grant. Grant funds covered site exploration to update design, obtain permits and prepare construction documents. The Greenpoint Monitor Museum USS Monitor Park Shoreline Design Project is made possible with funding provided by the Office of the NYS Attorney General and the NYS Department of Environmental Conservation through the Greenpoint Community Environmental Fund. Long terms next steps: (1) Work with city agencies on getting the site zoned to allow for a museum and park (2) Continue park design development (3) Begin design for museum and dock. Ms. Lauletta-Weinmann spoke about the history of the Monitor ship and the museum representatives before the board this evening were wearing period costumes from the Civil War, as Friends of Union Veterans of the Civil War. Mr. Weinmann spoke about Civil War period and regiments. Ms. Weinmann noted that they conduct various outreaches regarding the museum and conduct Civil War reenactments. She requested a letter of support from CB#1.

7. **LPC – APPLICATION REGARDING THE PROPOSED DEVELOPMENT OF PROPERTY WITHIN THE GREENPOINT HISTORIC DISTRICT, 171 Calver Street, Brooklyn, NY 11222** – by Sherida E. Paulsen, FAIA & Robert Bianco Architect AIA, PKSB Architects PC [Item was withdrawn by the applicant.]

8. **LIQUOR LICENSES:**

The following applications for liquor licenses were announced:

NEW

- 1) 76 Ainslie OPCO LLC, dba TBD, 76 Ainslie Street, (New, liquor, wine/beer, cider, rest)
- 2) 315 Meserole LLC, 315 Meserole Street, (New, liquor, wine/beer, cider, bar, tavern)
- 3) Authentic Pierogi Inc., dba TBD, 592 Manhattan Avenue, (New, liquor, wine/beer, cider)
- 4) Brich Cheese LLC., dba TBD, 667 Manhattan Avenue, (New, wine/beer, cider, rest)
- 5) Chuy's Cantina Inc. dba Pending, 366 Union Avenue, (New, liquor, wine/beer, cider)

- 6) Dolly's Swing & Dive Bar LLC, 101 Kent Avenue, (New, liquor, wine/beer, cider, bar, tavern)
- 7) Elite BK Inc., 128 Metropolitan Avenue, (New, liquor, wine/beer, cider, rest)
- 8) Elliot Brooklyn LLC, dba Sixty Sixth Congress, 66 Greenpoint Avenue, (New, liquor, wine/beer, cider, bar, tavern)
- 9) Fish Sauce Boys Inc., dba High Lva Vietnamese Kitchen, 743 Driggs Avenue, Store 1, (New, wine/beer, cider, rest)
- 10) Freedom Cruises LLC, dba Queen of Hearts, 200 Morgan Avenue, (New/Removal, liquor, wine/beer, cider, vessel, boat, ship)
- 11) JTF Eatery LLC, dba TBD, 1164 Manhattan Avenue, (New, liquor, wine/beer, cider, rest)
- 12) MJMRSR Corp., dba Julie's Kitchen, 159 Franklin Street, (New, wine, beer/cider, rest)
- 13) Riverwalk Management Inc. dba Naked Dog, 47 Java Street, (Corporate Change, liquor, wine/beer, cider, rest)
- 14) The Black Squirrel Crew LLC, 25-29 Thames Street, (New, wine/beer, cider, bar)
- 15) V.O.E Hospitality Group, dba Gentle Perch, 112 Graham Avenue, (New, liquor, wine/beer, cider, rest)

RENEWAL

- 1) 1073 Manhattan Avenue LLC, dba Lobster Joint, 1073 Manhattan Avenue, (Renewal, liquor, wine/beer, cider, rest)
- 2) 54N11BK LLC, dba Schimanski, 60 North 11th Street, (Renewal, liquor, wine/beer, cider, cabaret)
- 3) 222 Franklin Street LLC., dba Anella, 222 Franklin Street, (Renewal, liquor, wine/beer, cider)
- 4) 1073 Manhattan Ave LLC, dba Lobster Joint, 1073 Manhattan Avenue, (Renewal,
- 5) Artburger LLC, dba Eastwick, 112 Graham Avenue AKA 132 McKibbin St., (Renewal, liquor, wine/beer, cider, rest)
- 6) Bklyn Slovak American Citizen Club Inc., 619 Manhattan Avenue, (Renewal, liquor, wine/beer, cider, private club liquor)
- 7) Call Box Lounge Inc., 148 Kingsland Avenue, (Renewal, liquor, wine/beer, cider, rest)
- 8) Chickenbone Ltd., dba Dram, 177 South 4th Street, (Renewal, liquor, wine/beer, cider, tavern)
- 9) Cloacruz Inc., 39 Bushwick Avenue, (Renewal, liquor, wine/beer, cider, rest)
- 10) Family Group Enterprises Inc., dba Patrizia Pizza & Pasta, 35 Broadway, (Renewal, wine/beer, cider, rest)
- 11) F-C LLC, dba Chez Ma Tante, 90 Calyer Street, (Renewal, liquor, wine, beer, cider, rest)
- 12) Fidel Corp., dba Le Barriquou, 533 Grand Street, (Renewal, liquor, wine, beer, cider, rest)
- 13) Four Happy Men LLC, dba Loosie Rouge, 91 South 6th Street, (Renewal, liquor, wine/beer, cider, rest)
- 14) Garlic Knots 364 LLC, dba Emmy Squared, 364 Grand Street, (Renewal, liquor, wine/beer, cider, rest)
- 15) Green bottle LLC, dba Broke Land, 105 Franklin Street, (Renewal, liquor, wine/beer, cider, bar, tavern)
- 16) Musashi Asian Cuisine Inc., 495 Grand Street, (Renewal, wine/beer, cider, rest)
- 17) Nitehawk Brooklyn LLC., dba Nitehawk Cinema, 136 Metropolitan Avenue, (Renewal, liquor, wine/beer, cider, rest)
- 18) LPO Reality Inc. dba Raizes, 139 Nassau Avenue, (Renewal, liquor/wine, beer, cider, rest)
- 19) Pizzati LTD., dba Surf Bar, 139 North 6th Street, (Renewal, liquor, wine/beer, cider, rest)
- 20) Ramen on the Hill Inc., dba Andante, 255 Berry Street, (Renewal, wine/beer, cider, rest)
- 21) South of Heaven LLC, dba Diamond Lil, 179 Nassau Avenue, (Renewal, liquor, wine/beer, cider, bar, tavern)

- 22) Table for Eight Inc., dba M Noodle Shop, 549 Metropolitan Avenue, (Renewal, wine/beer, cider, rest)
- 23) Weylin B Seymour LLC, dba Weylin B Seymours/Chimera, 175 Broadway, (Renewal, liquor, wine/beer, cider, catering facility)

Chairperson Ms. Fuller noted the list and asked for any comments. There were two speakers on the topic.

Mr. Ray Gonzalez, spoke about his license for the Grand Morelos Restaurant on Grand Street. He introduced himself and was available to answer any questions. The license is a new one for beer. It would be reviewed at the next SLA Review & DCA Committee meeting. It was noted that the SLA Review and DCA Committee would meet on June 25, 2019 to conduct its review of the licenses.

The agenda was expedited in order for the members to conduct the regular board meeting.

BOARD MEETING

MOMENT OF SILENCE

Chairperson Ms. Fuller called for a moment of silence.

ROLL CALL

Chairperson Ms. Fuller requested District Manager Mr. Esposito to call the roll. He informed the chair that there were 33 members present, a sufficient number for a quorum to call the meeting to order.

OATH FOR NEW MEMBERS

Ms. Fuller welcomed the new members and asked them to come forward in order to receive the oath to be sworn on. Mr. D'Amato and Mr. Klagsbald came forward.

APPROVAL OF THE AGENDA

Mr. Caponegro made a motion to approve the agenda as written. The motion was seconded by Mr. Solano. The motion was unanimously carried.

APPROVAL OF THE MINUTES

Mr. Solano made a motion to approve the minutes of the May 14, 2019 combined Public Hearing and Board Meeting, as written with the additions noted by Mr. Elkins under new business. The motion was seconded by Ms. Cabrera. The motion was unanimously carried.

COMMITTEE REPORTS

Public Safety & Human Services Committee – Mr. Burrows announced that there would be two "National Night Out" events in CB#1 ["National Night Out" is an annual community-building campaign that promotes police-community partnerships to help make our neighborhoods safer, more caring places to live. It seeks to strengthen the relationship between neighbors and law enforcement, fostering a true sense of community]. The two events in CB #1 will be held on August 6th:

(1.) 94th Precinct: 4PM-8 PM on Lorimer Street, between Meserole Avenue and Calyer Street.

(2.) 90th Precinct: 5-8PM at the School Yard at 325 South 3rd Street.

Mr. Burrows also spoke about the scheduled Gay Pride Parade where 3-5 million people will be

participating. At this time there are no credible threats and there will be a lot of security around Manhattan. He asked all to be vigilant, and if someone hears of something, to contact the police.

SLA Review & DCA Committee – Mr. Burrows noted the committee’s written report. He read the report and made a motion requesting the board members to vote on the various portions. Mr. Torres seconded the motion.

I. Unenclosed Sidewalk Cafes:

Unenclosed Sidewalk Café: Bernie’s Point, 836 Lorimer Street, Application # 2998-2019-ASWC; 8 Tables; 16 Chairs, New. (Rep./Michael Kelly). The Committee recommends approval.

Unenclosed Sidewalk Café - Winsome Foods, LLC, dba Win Son, 159 Graham Avenue (#2019157-DC); 19 Tables; 38 Chairs, Renewal. (Rep./ Joshua Ku, Managing Member) The Committee recommends approval.

Unenclosed Sidewalk Café - 451 Graham Avenue Corp., dba The Richardson, 451 Graham Avenue, (#1314137 – DCA); 15 Tables, 30 Chairs, Renewal. (Rep./Joel Kulp, President) The Committee recommends approval.

Unenclosed Sidewalk Café: 600 Metropolitan Corp., dba Alligator Lounge, 600 Metropolitan Avenue (#1311871 – DCA); 6 Tables, 18 Chairs (Rep./John McGillion, President)

The Committee recommends denial. The applicant has violated the DCA regulations regarding unenclosed sidewalk cafés.

Unenclosed Sidewalk Café: D&D Café LLC, 128 Meserole Street, Application # 454-2019 ASWC; 19 Tables; 38 Chairs, New. (Rep./Shlomo Steve Wygoda, SWA Architecture PLLC). The Committee recommends denial unless applicant reappears. The vote of the Board was: 35 “YES”; 1 “NO” (Kuonen); 0 “ABSTENTIONS”; 0 “RECUSALS”. The motion was carried.

II. Liquor Licenses:

NEW:

1. 82 S4th Restaurant & Café, dba Casa Imelda, 82 South 4th Street, (Alteration, liquor, wine/beer). The Committee recommends denial.

2. 104 South 4TH Inc., dba Randolph Beer, 104 South 4th Street, (Class Change, liquor, wine/beer, cider, rest, brewer).The Committee recommends denial.

3. 147 149 McCarren LLC., dba McCarren Hotel, 160 N. 12th Street, (Alteration, Method of Operation Change, liquor, wine/beer, cider, hotel)

The Committee recommends approval with the proviso that the applicant resubmit a revised application.

4. 462 Union Avenue Bar LLC., dba Macri Park, 462 Union Avenue, (Corporate Change, liquor, wine/beer, cider, bar/tavern) – POSTPONED.

5. AL Sushi NY INC. dba Mizu Sushi, 311 Bedford Avenue, (New, wine/beer, cider, rest) Applicant did not appear. The Committee recommends denial.

6. Anaya Alam LLC, 318 Bedford Avenue, (New, wine/beer, cider, bar/tavern) – POSTPONED. Applicant/owner, is to appear at the next meeting of the committee.

7. Bernie’s Point LLC, dba Bernie’s, 836 Lorimer Street, (Alteration, liquor, wine/beer, cider, rest) The Committee recommends approval.

8. Domino Park F & B Management LLC, dba Tacocina, 292 Kent Avenue, (Method of Operations Change, liquor, wine/beer, cider, rest)

The Committee recommends approval, pending a letter from the park/property owner [Two Trees] and stipulations regarding the hours of operation.

9. Indigo Williamsburg HM LLC., dba TBD, 500 Metropolitan Avenue, (New, liquor, wine/beer, cider, Hotel).The Committee recommends approval. A revised application is to be submitted. Landscaping is to be provided.

10. Juicerie IV LLC, dba The Butcher's Daughter, 271 Metropolitan Avenue, (Alteration, liquor wine/beer, cider, rest). The Committee recommends approval.
11. La Guira Restaurant Corp., 580 Broadway, (New, liquor, wine/beer, cider, bar/tavern) – POSTPONED.
12. Michael Braman or Entity to be formed, 774 Driggs Avenue, (New, Wine/Beer, cider, rest) Applicant did not appear. The Committee recommends denial.
13. Original Music Workshop Inc. & The Middle LLC., dba National Sawdust OMW, 80 North 6th Street, (Alteration, liquor, wine/beer, cider, rest). The Committee recommends approval.
14. Ozi Dumplings, dba Ozi Dumplings, 19 Bogart Street, Unit 1, (New, Wine/Beer, cider, rest) The Committee recommends approval.
15. Pomp and Circumstance LLC, dba Pomp and Circumstance, 577 Lorimer Street, (New, liquor, wine/beer, cider, rest). The Committee recommends approval.
16. Secret Loft LLC., dba Secret Loft, 90 Scott Avenue, (New, liquor, wine/beer, cider, bar, tavern) POSTPONED, The Committee requests that they present to the full board at the June 11, 2019 meeting because they indicate having over 250 patrons.
17. TLP Brooklyn LLC, iOLO, 485 Lorimer Street, (New, liquor, wine/beer, cider, rest) The Committee recommends approval. Mr. Burrows made a motion to support the committee's various recommendations. The motion was seconded by Mr. Solano. The motion was carried unanimously.

Renewals:

1. 89 Conselyea Realty LLC., dba DeStefanos Steakhouse, 89 Conselyea Street, (Renewal, liquor, wine/beer, cider)
2. 170 Bedford Restaurant LLC, dba The Meatball Shop, 170 Bedford Avenue, (Renewal, liquor wine/beer, cider, rest)
3. Aleyin LLC., dba Café Beit, 158 Bedford Avenue, (Renewal, wine/beer, cider, bar, tavern)
4. Avago Corp., dba Berry Park, 4-6 Berry Street, (Renewal, liquor, wine/beer, cider, bar, tavern)
5. Avant Gardner LLC., dba Avant Gardner, The Great Hall, The Kings Hall, and The Brooklyn Mirage, 111 Gardner Avenue and 140 Stewart Avenue (Renewal, liquor, wine/beer, cider, multipurpose event center/venue) – The Committee recommends denial. *
6. Black Rabbit Bar LLC., dba Black Rabbit, 91 Greenpoint Avenue, (Renewal, liquor, wine/beer, cider, bar/tavern)
7. Bridge 109 Corp, dba Gordon Bennett, 109 South 6th Street, (Renewal, liquor, wine/beer, cider, rest)
8. Boogaloo Bar Inc. dba Duff's Brooklyn, 168 Marcy Avenue, (Renewal, liquor, wine/beer, cider, bar/tavern)
9. Brooklyn Bowl LLC, 61-77 Wythe Avenue, (Renewal, liquor, wine/beer, cider, rest)
10. Campbell Sister LLC, dba Campbell Cheese and Grocery, 502 Lorimer Street, (Renewal, wine/beer, cider)
11. Carrie's Hospitality LLC, dba Elder Greene, 160 Franklin Street, (Renewal, liquor, wine/beer, cider, bar/tavern)
12. Cervecería Havemeyer LLC, dba Cervecería Havemeyer, 149 Havenmeyer Street Store #3, (Renewal, liquor, wine/beer, cider, rest)
13. Coyocan Lorimer LLC, dba Zona Rosa, 571 Lorimer Street, (Renewal, liquor, wine/beer, cider, rest)
14. Davis and Devoe Group LLC, dba Teddy's Bar & Grill, 96 Berry Street, (Renewal, liquor, wine/beer, cider, rest)
15. Dingxiang Inc., dba Birds of Feather, 191 Grand Street, (Renewal, wine/beer, cider, rest)
16. Double Deep LLC., dba Black Flamingo, 168 Borinquen Place - Store S5, (Renewal, liquor, wine/beer, cider, rest)

17. Isleworth Management LLC, dba New Z & J Wine & Liquor, 761 Manhattan Avenue, (Renewal, liquor, wine/beer, cider) *This is a liquor Store.* **
18. Hinomaru Kitchen Inc., dba Ryujin Ramen, 513 Grand Street, (Renewal, wine/beer, cider, rest)
19. Los Cuantes LLC, dba Rosario, 168 170 Wythe Avenue, (Renewal, liquor, wine/beer, cider, rest)
20. Ott Bagel Inc., 970 Manhattan Avenue, (Renewal, wine/beer, cider, rest)
21. Our Wicked Lady LLC., dba Our Wicked Lady, 153 Morgan Avenue, (Renewal, liquor, wine/beer, cider, bar, tavern)
22. Polmost Food Corp, dba Associated, 802 Manhattan Avenue, (Renewal, beer/cider, supermarket). *This is grocery store.* **
23. Red House BK LLC, dba Kings County Imperial, 20 Skillman Avenue, (Renewal, liquor, wine/beer, cider, rest)
24. Sterling Caterers Inc., dba Ateres Avrohom, 75 Ross Street, (Renewal, liquor, wine/beer, cider)
25. WoodFoot LLC, dba Pokito, 155 South Street, Store #2, (Renewal, liquor, wine/beer, cider, rest)
26. Yurit S. Munoz and Eugenio Zenteno, dba Acapulco Restaurant Deli; 1116 Manhattan Avenue, (Renewal, beer, cider, rest)

The Committee recommends approval of the renewal licenses with the exception of:

* (#5.) - Avant Gardner LLC., dba Avant Gardner, The Great Hall, The Kings Hall, and The Brooklyn Mirage. This application is recommended for denial.

It was noted that items highlighted with ** [#17. & #22.] – Isleworth Management LLC, dba New Z & J Wine & Liquor; Polmost Food Corp, dba Associated – listings for establishments that were not on-premises licenses. They were not reviewed. Previously Postponed Items: The Black Squirrel Crew LLC, 25-29 Thames Street, (New, wine/beer, cider, bar). The Committee recommends approval.

Mr. Solano made a motion to support the various recommendations. The motion was seconded by Ms. Teague. The vote of the board was: 36 "YES"; 0 "NO"; 0 "ABSTENTIONS"; 0 "RECUSALS". The motion was unanimously carried.

Mr. Burrows noted that the committee is also requesting a letter to be sent to the NYC Night Life Mayor and NYPD requesting that this area of East Williamsburg be reviewed because there are a number of these late night venues within close proximity. There are public safety concerns with the crowds of people, traffic congestion and patrons traversing through the industrial area's streets and train tracks. They need more police at the precincts to handle these crowds. Ms. Cabrera made a motion to send the letter. The motion was seconded by Ms. Teague. The motion was unanimously carried.

District Manager Mr. Esposito noted that in the NYC's Department of Health and Mental Hygiene's newest copy of the "Health Profile for Greenpoint and Williamsburg", it is stated that the rate for Binge Drinking is 19%. In Brooklyn the rate is 15%, with Bensonhurst having the lowest (9%). NYC's overall rate is 17% and the major goal is to reduce that the figure to be below 17%. CB#1's rate is too high.

Environmental Protection Committee – Mr. Elkins presented a report. He related that they had a meeting last week on short notice because of demolition work that is planned for the Bushwick Inlet Park. The committee has concerns about the abatement and what steps are being taken to protect the community during the demolition of the former petroleum tanks. The tanks are empty. The committee discussed air monitoring and felt it was beneficial to conduct air monitoring during both preconstruction and construction given the legacy of pollution on the site, the nearby park and neighborhood. Mr. Elkins made a motion that CB#1 send a letter to the Parks Department and EDC stating that although the monitoring is not required, the board is requesting that air monitoring be done before and during demolition. This

monitoring should be incorporated into the plan. The motion was seconded by Ms. McKeever. The motion was unanimously carried.

(At 8PM, the committee's report was temporarily halted to allow for the Annual Elections Process)

ELECTIONS

Chairperson Fuller noted that it was time for elections. She requested that the members of the Elections Committee [Mr. Torres, Ms. Gallagher, Ms. Foster] come forward and distribute the ballots. Members were reminded to sign their ballots. The elections were for the Executive Committee and the Attendance Committee. The board members were each called by name and ballots were given to them individually. The ballots were collected by a roll call. The Elections Committee adjourned to the adjacent room to count the ballots.

(Environmental Protection Committee – report was resumed.)

Mr. Elkins discussed problems with petroleum vapors. This matter was raised at the committee during new business. The problem is happening in the northern part of Greenpoint. Residents are concerned. The source has not been identified. A meeting is happening tomorrow evening at 176 Java Street. Some flyers were distributed. Anyone concerned about this issue should attend the meeting. CB#1 sent a letter last month. He made a motion to send a more specific second letter to the appropriate agencies and elected officials requesting the agencies to investigate the odors and identify them by sampling in and around underground plumes in the area; have hydrologists conduct an evaluation of ground water movement; conduct an investigation into any increases in petroleum arriving at the sewage treatment plant. This is potentially a very big issue. A preschool program was evacuated because of the petroleum odors. Mr. Wilkins made a motion to send the letter. The motion was seconded by Ms. Kaminski. The motion was unanimously carried. Mr. Wilkins gave a shout out to the Moritor Museum for the design work that it is doing on the shoreline.

Land Use, ULURP and Landmarks Committee Report – Chairperson Fuller noted that there were speakers signed up for the land use items. They were asked to come forward and to speak.

- Barbara Hertel, resident of Broadway, spoke against the variance for the proposed development. The plans were confusing and deceptive. At the committee meeting, it went to three different votes. It was noted that an elevator was not shown at the top. She had concerns with the height and the number of stories,
- Brenda Hutchinson, resident of Broadway, spoke against the variance for the proposed development of 115 Broadway. The building is out of scale. She stated that the renderings were deceptive and confusing.

Ms. Teague delivered the committee's report. She noted that the committee was very divided on the 115 Broadway item. (The committee's report was paused to allow for the tally of votes to be announced)

ELECTIONS RESULTS - Chairperson Fuller announced the votes. (Attached is the Tally)

Executive Committee:

of votes

| | | | |
|----|----------------------------|---|---------------------|
| 24 | Chairperson | - | Dealice Fuller |
| 24 | 1 st Vice Chair | - | Simon Weiser |
| 24 | 2 nd Vice Chair | - | Del Teague |
| 24 | 3 rd Vice Chair | - | Stephen J. Weidberg |

| | | | |
|----|---------------------|---|---------------------|
| 24 | Financial Secretary | - | Maria Viera |
| 26 | Recording Secretary | - | Sonia Iglesias |
| 24 | Member at Large | - | Philip A. Caponegro |

Attendance Committee:

| # of votes | | | |
|------------|-----------------------|--|--|
| 29 | Rabbi David Niederman | | |
| 30 | Eric Bruzaitis | | |
| 30 | Janice Peterson | | |

Chairperson Ms. Fuller thanked all of the board members so very much.

The Land Use Committee Report (Continued) – Ms. Teague continued the committee’s report (attached). She related that the committee was concerned about the defacto outdoor café without permits. This was debated in the committee.

BSA ITEM # 2019-73-BZ 115 BROADWAY, BLOCK 2471 LOT 13 – Application for a variance to facilitate development of new six story plus mezzanine mixed use building at 115 Broadway. (Rep./Slater & Beckerman PC)

Recommendation: She related that the committee was concerned about the defacto outdoor café without permits. This was debated in the committee. Ms. Teague said that she was concerned about what would be given back to the community. After much discussion the committee voted [6 in favor, 1 opposed, 2 abstentions] to recommend:

- (1.) approval of (a) the request for waiver of ZR 23-32 (minimal lot area for residences), and (b) ZRs 35-31 and 23-153 (maximum floor area ratio for Quality Housing building);
- (2.) approval in part of the request for waiver of ZRs 35-31 and 33-122 (maximum total floor area ratio for mixed use building) on the condition that the developer bring the height of the building from 102 feet, 2 inches down to 86 feet (70 feet from ground to roof, plus 16 feet for the bulkhead); and
- (3.) denial of the request for waiver of ZRs 35-652 and 23-662 (maximum base height, maximum total height, and required setbacks for mixed use building).

In sum, the committee recommends denying that part of the variance that would allow the requested height of 102 feet, but not opposing allowance of a development on the site, if the total height is reduced to 70 feet to the roof, plus a 16 foot bulkhead. In addition the committee voted to condition the approvals on the requirement that the applicant communicate with DOT regarding taking over maintenance of the plaza and agree to refrain from having a bar on the ground floor.

The board members discussed the recommendation and debated the many points that were raised. Ms. Teague restated the recommendation that would so deny so much of the application. She made the motion to support the committee’s recommendation. The motion was seconded by Mr. Weidberg. The vote was called. The vote was: 3 "YES"; (Cabrerias; Solano; Gross) 32 "NO"; 1 "ABSTENTION" (Nieves); 0 "RECUSALS". The motion failed. There was another motion raised to deny the application. Mr. Sofer made the motion to deny the application. Ms. Teague seconded the motion. The vote was: 33 "YES"; 1 "NO" (Stuart); 2 "ABSTENTIONS" (Nieves; Weiser); 0 "RECUSALS". The motion was carried.

BSA ITEM #2019-95-BZ) 19 MASPETH AVENUE, AKA 220 CONSELYEA STREET, BLOCK 2893 LOTS 1 & 15 – Ms. Teague noted that the committee caucused after the presentation made on the item by the applicant and there was a unanimous recommendation to vote to disapprove the application

(deny with conditions). Conditions - unless the applicant to provide three affordable apartments; 2 1-bedroom; 1 2-bedroom; up to 60% AMI; and that they would conduct a full archeological study with a qualified archeologist. The board members discussed the recommendation. Mr. Needleman made a motion to deny the application unless they meet the conditions. Mr. Weiser seconded the motion. The motion was carried. The vote was: 32 "YES"; 0 "NO"; 3 "ABSTAINED" (Rachlin; Cabrera; D'Amato); 0 "RECUSALS".

Ms. Teague continued with the committee's report. She announced that the committee received a briefing a potential application to rezone small area from C8-2 and R6B/C2-4 to R7A/C2-4 to enable residential MIH development at 824 Metropolitan Avenue. A vote was not needed as the application has yet to be filed.

77 COMMERCIAL STREET (N 190327 CMK, N 190258 CMK & N 190262 CMK) Renewal of previously approved special permit C 140047 ZSK and authorizations N 140048 ZAK & N 140049 ZAK

– This request is a renewal of a special permit. The board has previously voted on it. The board members discussed the action and the previous recommendation. There were concerns about the development. Ms. Teague spoke about what the board had requested in the previous recommendation; that it include affordable housing. It was noted that apartments for seniors is in great need. Ms. Kaminski made a motion to continue with the board's previous position to disapprove with modifications/conditions. The motion was seconded by Mr. Weidberg. The motion was carried. There were four abstentions (Rachlin; Kuonen; Wilkins; Gallagher).

POPS (N190408 ZRY) – Proposed Privately Owned Public Spaces – Signage & Amenities Text Amendment

– Ms. Teague discussed the application and the request for feedback on the action. City Planning is seeking feedback. They are proposing to change the signage's appearance, symbols and the colors to be clearer. She noted that she didn't see anything that was a problem with it. She asked for comments. A vote is not needed. She asked for any comments to be forwarded to her attention by July 1st. Comments are to be submitted to the agency by July 15th. The information will be sent again to the members to review. Ms. Teague made a motion for members to submit their comments and that the board would forward them to the Department of City Planning by July 15th. The motion was seconded by Mr. Weidberg. The motion was unanimously carried.

Transportation Committee – Mr. Bruzaitis submitted a written report on behalf of the Transportation Committee. He reviewed the report and noted a vote was needed for a car service's base license renewal. Mr. Bruzaitis made a motion to support the renewal for the base license for Brooklyn Radio Dispatcher Inc., at 232 Metropolitan Avenue (#1), Brooklyn, NY 11211. The motion was seconded by Ms. Nieves. The vote was as follows: 36 "YES"; 0 "NO"; 0 "ABSTENTIONS"; 0 "RECUSALS".

Parks Committee Report – Mr. Caponegro submitted a written report. The Committee received a final presentation of the Design for the Box Street Park by the Parks Department. He asked all to review the report. The committee did not achieve a quorum. The Committee members present voted 4-0 to accept the design with the following recommendations:

- 1.) All environmental information is presented to the Community Board.
- 2.) Enlarge the width of the stepdown.
- 3.) Metal grates along the walkway over the water.
- 4.) Add more seating along the waterfront.
- 5.) Adding wood benches.

He made a motion to support the report. The motion was seconded by Ms. McKeever. The motion was unanimously carried. Mr. Caponegro also gave a shout to the Monitor Museum, to get it going. Chairperson Fuller noted that a request has come to support the Monitor Museum's efforts. Mr. Caponegro made the motion for the letter of support. The motion was seconded by Ms. Cabrera. The motion was unanimously carried.

Budget Committee – Mr. Weidberg announced that the committee will be drafting the District Needs Statement for 2021 and compiling budget priorities. He was seeking comments from the board members and the public. He asked that comments be provided to the committee in writing. The Committee will be meeting on June 26th; and plan to discuss budget consultations. There will be another meeting sometime in the summer. Ms. Gallagher asked about the budget committees. In the By Laws, it notes two budget committees. One for the board's budget and the other for how to use the district budget. Mr. Weidberg related that he only does the capital budget.

Ms. Viera, the Financial Secretary, spoke on the matter of the board's budget. She said that they could incorporate a meeting to discuss the proposed budget. She only has the information as to the expenditures to OTPS (other than personal expenses). She could share the proposed budget and this something that they could do prior to June 30th. It has to be submitted by June 30th. Ms. Viera related that the committee has not met yet. The members discussed the budget and the committee. Ms. Viera said the committee is being formed. The committee will start again in September but members could be recruited now. There was a discussion by members on providing monthly reports and approvals of the budget. Ms. Viera said that they can only improve moving forward. Chairperson Fuller noted that she appoints members to committees. The forms will be going out for members to apply for committees. Members need to check off if they want to be on the [board budget] committee. She will consider the committee appointments. There are 14-15 committees. Another one will be added. She reminded all that they need to attend the committee meetings that they are appointed to. Chairperson Fuller noted that the new list of board members was just received from the Borough President (and the City Council). She said that the forms will be going out shortly. She asked for the members to return the forms as soon as possible.

PARKS DEPARTMENT MINUTE

Ms. Salig submitted a written report that was distributed for review.

PUBLIC SESSION (Reserved for the Public's expression. Board Members will not be allowed to speak.) Each scheduled participant for this session will have an allowance of two (2) minutes. (No questions will be entertained. Speakers are requested to submit their testimony in writing) Persons had signed up for the public and were given the opportunity to speak.

Ms. Lauren Comita, spoke about the public library and the need for funding. She related some programs happening over the Summer.

Ms. Maureen Bown, from the Brooklyn Hospital Center spoke about the WIC Program.

Ms. Rifka Friedmen, spoke about summer hours at Metropolitan Pool, for women's swim. She related the need for those who are handicapped.

Ms. Bella Sabel, spoke about women's swim at Metropolitan Pool, asking for two hours of the fifteen hours available.

Ms. Deborah Spiroff, spoke about the board's vehicle.

Mr. Austin Horse, spoke about the board's vehicle and public funds.

Ms. Anna Marie Wolf, spoke about the board's vehicle and use of public funds.

Ms. Paulette O'Neal, spoke about a Jazz music event at the Devoe Street Baptist Church.
Mr. Gideon Solomon, spoke about the board's vehicle.
Ms. Stacy Cole, spoke about parking meters on Manhattan Avenue, Union Avenue, Lorimer Street, Leonard Street & Grand Street their impact on the community.
Mr. Mike Cherepko, spoke about the board's vehicle.
Mr. Kevin L. Cerra, spoke about the board's vehicle.
Ms. Sarah Lilley, spoke about the board's by-laws. She spoke about financial reporting.
Ms. Francoise Olivas, spoke about the board's vehicle; and purchasing air monitors.
Mr. Tommy Torres announced the Summer Youth Employment Program.
Mr. Jahl Rose, spoke about the Civilian Complaint Review Board.

CHAIRPERSON'S REPORT

A written report was distributed for review. Chairperson Fuller related that they had a great discussion at the Executive Committee meeting. They voted on committee reports behind that meeting. She hoped all had an opportunity to read it.

She said that we can do better and will do better. She appreciated what everything everybody said. It is taken to heart and under consideration. After that meeting a list of the budget monies that have to be spent by the end of this month. Suggestions were requested on spending the balance of the monies. The list was sent to the proper agency to see how to spend the money, if the items were doable, and if they were allowed to spend the money on it. No response has been received yet from the agencies on how to proceed. It was noted that if the money was not spent, it goes back to the City. Chairperson Fuller spoke about protocol on spending the money. The board followed the established protocol.

Ms. Foster spoke about the need to have the members focus on the meeting and not have private conversations during the meeting. She wanted to move forward. She said that if an item is purchased, you cannot send the item back...you don't get the money back. She urged to have respect for the Chairperson when she is speaking. She noted that the members were volunteers. Ms. Rachlin spoke about decorum. She spoke about protocols, process, what was being done moving forward. The members continued to discuss the matter further, including rules of engagement. Ms. Viera noted that there are some forms of expression that is cultural different. She urged all to be respectful of each other.

FINANCIAL SECRETARY'S REPORT

Ms. Viera provided a briefing on the budget and the various items. She noted some items have to be submitted to OMB before June 30th. The fiscal year ends June 30th. She discussed the items, which were expenses. The amount for the OTPS was \$10,476. She wasn't going to discuss the whole listing because some of it can be modified. Some items like internet and telephone have to be approved before July 1st. Line items like rent have to be approved before July 1st. She reviewed the list which included expenses for telephone, internet, rent (a bulk expense), alarm services, copy services, water, newspaper (The Chief), postage meter, (etc.). Ms. Kaminski made a motion to approve those items. The motion was seconded by Mr. Caponegro. The motion was unanimously carried.

DISTRICT MANAGER'S REPORT

A written report was submitted and distributed for review.

ANNOUNCEMENTS; ELECTED OFFICIALS

Representatives from elected officials had signed in to be acknowledged.

OLD BUSINESS

No old business was raised.

NEW BUSINESS

No new business was raised.

ADJOURNMENT

Ms. Kaminski made a motion to adjourn the board meeting. The motion was seconded by Ms. Teague. The motion was unanimously carried. The board meeting was adjourned.

Respectfully submitted,

Marie Bueno Wallin
Assistant District Manager

Reviewed by:

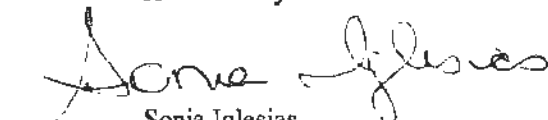
Sonia Iglesias
Recording Secretary

**BROOKLYN COMMUNITY BOARD # 1
OFFICIAL BALLOT ANNUAL ELECTION
JUNE 11, 2019**

| | CHAIRPERSON | FIRST VICE CHAIRPERSON | SECOND VICE CHAIRPERSON | THIRD VICE CHAIRPERSON | FINANCIAL SECRETARY | RECORDING SECRETARY | MEMBER AT LARGE | ATTENDANCE COMMITTEE | | |
|----|--------------------------|---------------------------|----------------------------|---------------------------|------------------------|------------------------|-------------------------|--------------------------|----------------|-----------------|
| | Dealice Fuller | Simon Weiser | Del Teague | Stephen J. Weidberg | Maria Viera | Sonia Iglesias | Phillip A. Caponegro | Rabbi David Niederman | Eric Bruzaitis | Janice Peterson |
| 1 | Gina Argento | ABSENT | ABSENT | ABSENT | ABSENT | ABSENT | ABSENT | ABSENT | ABSENT | ABSENT |
| 2 | Bojdan Bachorowski | ABSENT | ABSENT | ABSENT | ABSENT | ABSENT | ABSENT | ABSENT | ABSENT | ABSENT |
| 3 | Lisa Bamonte | X | X | X | X | X | X | X | X | X |
| 4 | Louis Barricelli | ABSENT | ABSENT | ABSENT | ABSENT | ABSENT | ABSENT | ABSENT | ABSENT | ABSENT |
| 5 | Gina Barros | X | X | X | X | X | X | X | X | X |
| 6 | Eric Bruzaitis | X | X | X | X | X | X | X | X | X |
| 7 | Thomas J. Burrows | NO VOTE | NO VOTE | NO VOTE | NO VOTE | NO VOTE | NO VOTE | NO VOTE | NO VOTE | NO VOTE |
| 8 | Iris Cabrera | | | | | X | | | | |
| 9 | Philip Caponegro | X | X | X | X | X | X | X | X | X |
| 10 | Frank P. Carbone | X | X | X | X | X | X | X | X | X |
| 11 | Stephen Chesler | | | | | | | X | X | X |
| 12 | Michael Chirichella | ABSENT | ABSENT | ABSENT | ABSENT | ABSENT | ABSENT | ABSENT | ABSENT | ABSENT |
| 13 | Theresa Cianciotta | ABSENT | ABSENT | ABSENT | ABSENT | ABSENT | ABSENT | ABSENT | ABSENT | ABSENT |
| 14 | Joshua Cohen | ABSENT | ABSENT | ABSENT | ABSENT | ABSENT | ABSENT | ABSENT | ABSENT | ABSENT |
| 15 | Giovanni D'Amato | NO VOTE | NO VOTE | NO VOTE | NO VOTE | NO VOTE | NO VOTE | NO VOTE | NO VOTE | NO VOTE |
| 16 | Arthur Dybanowski | ABSENT | ABSENT | ABSENT | ABSENT | ABSENT | ABSENT | ABSENT | ABSENT | ABSENT |
| 17 | T. Willis Elkins | | | | | | | X | X | X |
| 18 | Julia Amanda Foster | X | X | X | X | X | X | X | X | X |
| 19 | Dealice Fuller | X | X | X | X | X | X | X | X | X |
| 20 | Emily Gallagher | | | | | | | X | X | X |
| 21 | Vincent Gangone | ABSENT | ABSENT | ABSENT | ABSENT | ABSENT | ABSENT | ABSENT | ABSENT | ABSENT |
| 22 | Joel Goldstein | ABSENT | ABSENT | ABSENT | ABSENT | ABSENT | ABSENT | ABSENT | ABSENT | ABSENT |
| 23 | Solomon Green | ABSENT | ABSENT | ABSENT | ABSENT | ABSENT | ABSENT | ABSENT | ABSENT | ABSENT |
| 24 | Joel Gross | X | X | X | X | X | X | X | X | X |
| 25 | Sonia Iglesias | X | X | X | X | X | X | X | X | X |
| 26 | Moishe Indig | X | X | X | X | X | X | X | X | X |
| 27 | Bozena Kaminski | X | X | X | X | X | X | X | X | X |
| 28 | Avrom Katz | X | X | X | X | X | X | X | X | X |
| 29 | William Klagsbald | X | X | X | X | X | X | X | X | X |
| 30 | Ryan Kuonen | | | | | | | X | X | X |
| 31 | Yoel Landau | ABSENT | ABSENT | ABSENT | ABSENT | ABSENT | ABSENT | ABSENT | ABSENT | ABSENT |
| 32 | Marie Leanza | | | | | X | | | X | X |
| 33 | Yoel Low | ABSENT | ABSENT | ABSENT | ABSENT | ABSENT | ABSENT | ABSENT | ABSENT | ABSENT |
| 34 | Trina McKeever | | | | | | | X | X | X |
| 35 | Toby Moskovits | ABSENT | ABSENT | ABSENT | ABSENT | ABSENT | ABSENT | ABSENT | ABSENT | ABSENT |
| 36 | Martin Needelman | NO VOTE | NO VOTE | NO VOTE | NO VOTE | NO VOTE | NO VOTE | NO VOTE | NO VOTE | NO VOTE |
| 37 | Rabbi David Niederman | X | X | X | X | X | X | X | X | X |
| 38 | Karen Nieves | X | X | X | X | X | X | X | X | X |
| 39 | Mary Odomirok | X | X | X | X | X | X | X | X | X |
| 40 | Janice Peterson | ABSENT | ABSENT | ABSENT | ABSENT | ABSENT | ABSENT | ABSENT | ABSENT | ABSENT |
| 41 | Dana Rachlin | NO VOTE | NO VOTE | NO VOTE | NO VOTE | NO VOTE | NO VOTE | NO VOTE | NO VOTE | NO VOTE |
| 42 | Michael Gary Schlesinger | X | X | X | X | X | X | X | X | X |
| 43 | Isaac Sofer | X | X | X | X | X | X | X | X | X |
| 44 | Robert Solano | NO VOTE | NO VOTE | NO VOTE | NO VOTE | NO VOTE | NO VOTE | NO VOTE | NO VOTE | NO VOTE |
| 45 | James Stuart | X | X | X | X | X | X | X | X | X |
| 46 | Del Teague | X | X | X | X | X | X | X | X | X |
| 47 | Tommy Torres | X | X | X | X | X | X | X | X | X |
| 48 | Maria Viera | X | X | X | X | X | X | X | X | X |
| 49 | Stephen Weidberg | X | X | X | X | X | X | X | X | X |
| 50 | Simon Weiser | X | X | X | X | X | X | X | X | X |
| | TOTAL VOTES | 24 | 24 | 24 | 24 | 26 | 24 | 29 | 30 | 30 |

* No Vote Indicates that the ballot was submitted unmarked

* TOTAL BALLOTS CAST 35



COMMUNITY BOARD NO. 1
 435 GRAHAM AVENUE - BROOKLYN, NY 11211
 PHONE: (718) 389-0009
 FAX: (718) 389-0098
 Email: bk01@cb.nyc.gov
 Website: www.nyc.gov/brooklyn1



ATTENDANCE SHEET

(26 Members Constitute a Quorum for the Board Meeting & Public Hearing) DATE: Tuesday June 11, 2019

BOARD MEETING AND PUBLIC HEARING

| | | | |
|---------------------|------------------------|--------------------------|---------------------------|
| GINA ARGENTO | - out - | MOISHE INDIG | <i>M Indig</i> |
| BOGDAN BACHOROWSKI | - out - | BOZENA KAMINSKI | <i>B Kaminski</i> |
| LISA BAMONTE | <i>L Bamonte</i> | AVROM KATZ | <i>A Katz</i> |
| LOUIS BARRICELLI | - out - | WILLIAM KLAGSBALD | <i>W Klagsbald</i> |
| GINA BARROS | <i>G Barros</i> | RYAN KUONEN | <i>R Kuonen</i> |
| ERIC BRUZAITIS | <i>E Bruzaitis</i> | YOEL LANDAU | <i>Y Landau</i> |
| THOMAS J. BURROWS | <i>T Burrows</i> | MARIE LEANZA | <i>Marie Leanza</i> |
| IRIS CABRERA | <i>I Cabrera</i> | YOEL LOW | <i>Y Low</i> |
| PHILIP CAPONEGRO | <i>P Caponegro</i> | TRINA MCKEEVER | <i>T McKeever</i> |
| FRANK CARBONE | <i>F Carbone</i> | TOBY MOSKOVITS | - out - |
| STEPHEN CHESLER | <i>S Chesler</i> | MARTIN NEEDELMAN | <i>M Needelman</i> |
| MICHAEL CHIRICHELLA | - out - | RABBI DAVID NIEDERMAN | <i>Rabbi D Niederman</i> |
| THERESA CIANCIOTTA | - out - | KAREN NIEVES | <i>K Nieves</i> |
| JOSHUA COHEN | - out - | MARY ODOMIROK | <i>Mary Odomirok</i> |
| GIOVANNI D'AMATO | <i>G D'Amato</i> | JANICE PETERSON | - out - |
| ARTHUR DYBANOWSKI | - out - | DANA RACHLIN | <i>Dana Rachlin</i> |
| T. WILLIS ELKINS | <i>T Willis Elkins</i> | MICHAEL GARY SCHLESINGER | <i>M Gary Schlesinger</i> |
| JULIA AMANDA FOSTER | <i>J Foster</i> | ISAAC SOFER | <i>I Sofer</i> |
| DEALICE FULLER | <i>D Fuller</i> | ROBERT SOLANO | <i>R Solano</i> |
| EMILY GALLAGHER | <i>E Gallagher</i> | JAMES STUART | <i>J Stuart</i> |
| VINCENT GANGONE | - out - | DEL TEAGUE | <i>Del Teague</i> |
| JOEL GOLDSTEIN | - out - | TOMMY TORRES | <i>T Torres</i> |
| SOLOMON GREEN | - out - | MARIA VIERA | <i>M Viera</i> |
| JOEL GROSS | <i>J Gross</i> | STEPHEN WEIDBERG | <i>S Weidberg</i> |
| SONIA IGLESIAS | <i>S Iglesias</i> | SIMON WEISER | <i>S Weiser</i> |

Council Member
 Stephen T. Levin

Council Member
 Antonio Reynoso

ULURP, CALENDAR OR REFERENCE #: 2019-95-BZ
 APPLICANT: Capscar III LLC
 LOCATION: 19 Maspeth Avenue, Brooklyn
 REQUEST: BSA variance (ZR 72-21) to facilitate new 6 story
retail and residential building.

COMMUNITY BOARD NO. 1 QUESTIONNAIRE FOR LAND USE ITEMS

(Please complete this questionnaire and return to District Manager Gerald A. Esposito at
 CB #1's Headquarters, 435 Graham Avenue, Brooklyn, New York 11211.
 Feel Free to contact the Board's Office at (718) 389-0009
 if you have any questions or require additional information

PROPOSED ACTION: What is the proposed ULURP, or BSA action (i.e. an amendment to the zoning map, a siting of a city facility, a zoning variance, etc.)? This is an application
 to the Board of Standards and Appeals (BSA) for a variance (ZR 72-21) to facilitate development of new 6
 story retail and residential building having approx. 17,384 sf of zoning floor area.

1. For Ownership:

- a) Who are the owners? Capscar III LLC
- b) If a corporation, who are the principles? Paul Scarola and Joe Caputo are principals of Capscar III LLC.
- c) What kind of a corporation? An LLC

2. For Developers:

- a) Who is the developer if it is different than the owner? N/A
- b) What is their experience with this type of development? _____
- c) Is there a sponsor(s) of the project (i.e. a CBO, NYC Housing Partnership, NYCHA)? N/A

3. Financing:

- a) What is the cost of the project? The project's costs are expected to total \$10M, including land acquisition costs.
- b) How is it financed? Conventional lender
- c) Will there be tax abatements? Subsidies? _____

4. Land:

a) What information can be provided about the land? Who owns the land? _____

Capscar III LLC

b) What is the condition, status and uses on the property and the zoning? Use groups? _____

The property is currently vacant, and has been so for many decades. We are building a mixed use project including residential (Use Group 2) and retail (Use Group 6) uses. The property is zoned C8-2.

c) Has there been an environmental assessment or scope of an impact statement prepared for the proposed action? Yes, an Environmental Assessment Statement prepared by

BFJ Planning, was prepared and submitted to the BSA as part of the special permit application.

d) Will the land be purchased? What is the cost of the land? _____

When was the property purchased? March, 2015 What was the cost? \$1.35M

e) Will demolition be needed to clear the land? No, the property has been vacant since at least the 1982 but possibly longer.

f) Is the project in a special district? Historic District? Is it in an Urban Renewal Area? No.

g) Will unused development rights be utilized or sold (i.e. air rights)? No.

5. Construction:

a) What type of construction will be used (i.e. rehab/new) and methods (i.e. pre-form cast concrete, brick)? _____

Poured concrete

b) What is the time frame of the work (i.e. begin/end, etc.)? _____

24 months from start of construction

c) Who will be doing the work (i.e. firm, sweat equity, student interns)? _____

Qualified contractors

6. Project Information:

a) Describe the project in terms of the proposed use(s) such as retail, office, commercial, loft, community facility, etc.)? _____

The proposed building includes ground floor retail below 15 residential units.

b) If the project is residential, how many dwelling units are proposed and what is the number of bedrooms mix? What are the unit sizes?

15 total residential units. Each floor will have one two-bedroom and two one-bedroom apartments.

c) What are the projected costs of the rentals? If the units are to be condominium or one-to-three family house, what is the projected purchase price?

We have not yet set pricing but expect to be in line with the market

d) Will there be financing for the units? What are the terms?

N/A

e) Who is the lender? N/A

7. Marketing:

a) How will the project be marketed? Advertised? Through typical outlets for similar projects.

b) If newspaper, which ones?

c) When will the projects be marketed (before, during or after construction)?

During construction

d) What will be the outreach?

8. Project Characteristics:

a) Will the project be consistent with the surrounding buildings (i.e. height, FAR/Floor Area Ratio, conforming)?

Yes, the building will be similar in height to other new construction residential buildings in the surrounding area.

b) Will the project be handicap accessible? Explain specifics

Yes, per all applicable laws.

c) Special populations for the project (i.e. homeless, low-income, SRO, etc.)

N/A

9. Open Space/Parking Amenities:

a) Will there be open space provided with the project? What type (i.e. rear yard, park, waterfront)? Will there be public access? _____

No.

b) Will there be landscaping? Fencing? Street tree planting? _____

Yes, street tree planting.

c) Will parking be provided for (indoor, outdoor, on-street)? Will a waiver be requested? _____
No and no.

d) What amenities, if any, will be incorporated with the project? How were they developed and with who (i.e. tenants, residents, community group)? _____

Due to the small size of the development no amenities will be provided.

10. Building/Lot – currently undergoing any renovations, demolition, construction (of any size)?

N/A

11. Any violations on the building or lot (i.e. Department of Buildings, Department of Environmental Protection, EPA, etc.)?

N/A

12. In addition to the BSA's Environmental Report (or similar document) please provide the following information:

a) List previous industrial uses and processes: _____ Auto-related uses in the early 20th century.

b) List chemicals and quantities used in and stored for those processes: N/A

c) List Hazardous Waste Disposal permits for prior operators: N/A

d) List any proposed remediations: Not known at this time.

e) Please provide any ASTM Phase I & II information: N/A

PREPARED BY: Benjamin Stark TITLE: Applicant representative
SIGNATURE: _____ DATE: _____
CONTACT # () 212-391-8045 FAX # () _____

**Community Board #1
Supplemental Land Use Application Information**

Special permit actions - on a separate sheet, list all waivers, etc. requested

A. Project size
Commercial: (sq ft) 2,468 SF of commercial floor area
Manufacturing (sq ft) _____
Residential (sq ft) 14,916 SF of residential floor area
Total (sq ft) 17,384 SF of total floor area
Height (feet) ~60' (per Zoning Resolution)
Height (stories) 6

(for projects with more than one building, provide the the above data for each building)

B. Residential projects

| | Σ # of units | # affordable |
|--------------------|---------------------|--------------|
| 0 bedroom (studio) | <u>10</u> | _____ |
| 1 bedroom | <u>5</u> | _____ |
| 2 bedroom | _____ | _____ |
| 3 bedroom | _____ | _____ |
| ≥4 bedroom | <u>15</u> | _____ |
| Total units | _____ | _____ |

Market-rate units Rental
Rental or condo? _____
Estimated cost/rent psf TBD
(market rate units only)

Affordable units N/A
Rental or condo? _____
Distribution of affordability by % of AMI

C. Open space

| | required | proposed |
|---------------------|----------|----------|
| Total area | _____ | _____ |
| Publicly accessible | _____ | _____ |

What are the hours of accessibility for the publicly-accessible open space? _____

Will the publicly-accessible open space be turned over the Department of Parks for operation?

D. Parking

Parking - number of spots, number required by zoning

| | required | proposed |
|-------------|----------|----------|
| # of spaces | <u>0</u> | <u>0</u> |

E. Environmental

List all environmental issues identified, environmental designations (Little 'E', HAZMAT, brownfield, Super Fund, etc.) and all remediation required _____

F. Additional information

For all projects, please provide the following information:

- Draft or final EAS/EIS (pdf and one hard copy)
- 15 copies of power point presentation (11 x 17) to meeting
- Copies of power point presentation, architectural plans and renderings (pdf)
- NYS DEP signoff or status letter (waterfront sites only, pdf)
- List of project team (architect, engineer, landscape architect, code consultant, counsel, et al)
- List of all partners, corporation members, shareholders on ownership/development team
- Contact information (name, telephone, fax and email)

19 Maspeth Avenue, Brooklyn



- Application to Board of Standards and Appeals for Variance (ZR 72-21) under BSA Cal. No. 2019-95-BZ.
- Grant of variance would facilitate development of new 6 story building (17,384 sf; 5.85 FAR) on the approximately 2,967 sf triangular-shaped lot located at the confluence of Maspeth Avenue, Woodpoint Road, and Conselyea Street.
 - Mixed Use: Ground floor commercial (approx. 2,468 sf of retail below five stories of residential (totaling approx. 14,916 sf) across 15 total units (three per floor). Apartments consist of 10 one-bedroom units and 5 two-bedroom units.
 - Approx. 60' tall building.
 - No parking or residential amenities.
- C8-2 zoning district. Permits 2.0 FAR commercial; 4.8 FAR community facility.
- Waiver of C8-2 district's use regulations is necessary. Approx. 1.05 FAR of additional FAR needed as well.

Project Team:

- Application submitted by Capscar III LLC, owner of the property and an entity controlled by Joe Caputo and Paul Scarola the owners of New York Heating Corp and other local businesses.
- Consultants:
 - Architect: Edward I Mills and Associates
 - Environmental Consultant: BFJ Planning
 - Counsel (for BSA Application): Slater & Beckerman, PC

Location: Confluence of Maspeth, Woodpoint and Conselyea



Location: Confluence of Maspeth, Woodpoint and Conselyea



Zoning: c8-2

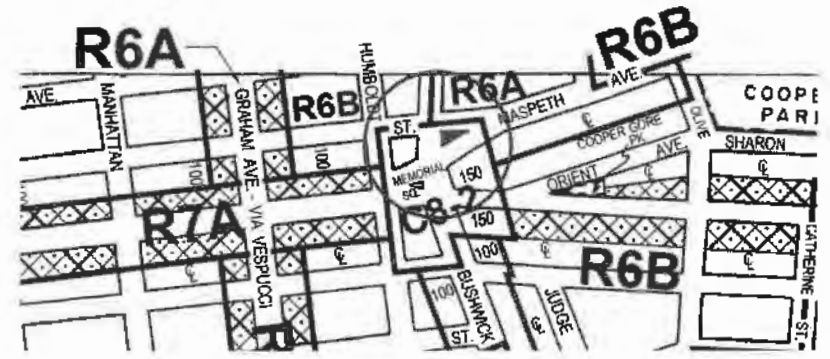

Site Challenges: Small size, irregular shape, and high proportion of primary frontage increases development costs. Irregular shape creates layout inefficiencies.

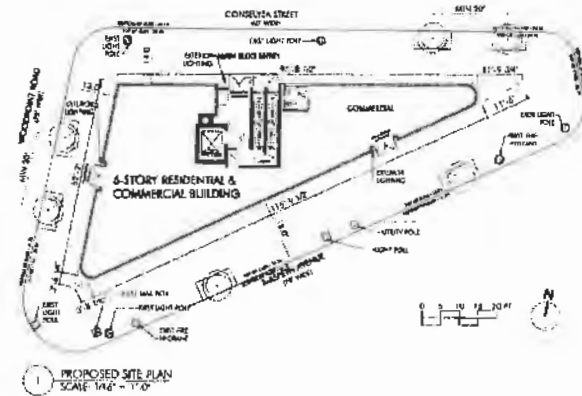

Surrounding Area:

Predominantly residential. Mix of older wood frame homes and new construction consistent with "R6A" zoning adjacent to site.





Proposed Building:

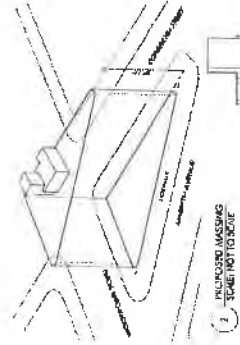

1. EXISTING BUILDING
2. EXISTING DRIVEWAY

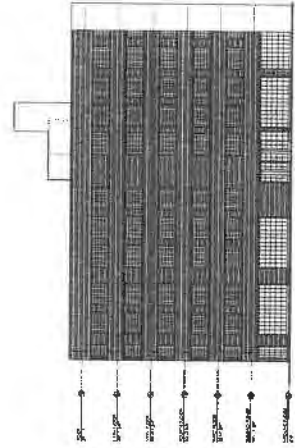

3. EXISTING BUILDING
4. EXISTING DRIVEWAY

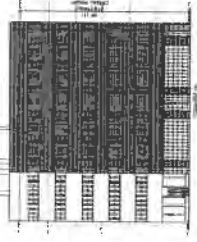

5. EXISTING BUILDING
6. EXISTING DRIVEWAY

Thank you.

THE GREENPOINT MONITOR MUSEUM ECOLOGICAL SHORELINE

COMMUNITY BOARD 1 INFORMATIONAL UPDATE



AECOM

AGENDA

SITE OVERVIEW

SITE ISSUES

RESPONDING TO THE SITE

ECOLOGICAL SHORELINE

NEXT STEPS

1.0 SITE OVERVIEW

1.1 INTRODUCTION SITE CONTEXT



1.2 INTRODUCTION SITE LEGACY



Page 5

1.3 INTRODUCTION GCEF GOALS

The ecological shoreline is funded through the Greenpoint Community Environmental Fund (GCEF)

GCEF goals:

- **Enhance open space**
- **Green buildings, infrastructure, and neighborhoods**
- **Restore the waterfront**
- **Promote environmental education and stewardship**



**GREENPOINT
COMMUNITY
ENVIRONMENTAL
FUND**

Page 6

1.4 INTRODUCTION PROJECT GOALS

The Greenpoint Monitor Museum, through the GCEF grant, is:

- **Creating an ecological shoreline** with ecological restoration and stabilization techniques
- **Enhancing educational programs** by incorporating the environmental design process into their teaching curriculum
- **Developing a long term site vision** including a park and museum that will be open to the public
- **Working with designers and engineers** to complete design documentation for the ecological shoreline



Page 7

1.5 INTRODUCTION PROJECT BREAKDOWN



ECOLOGICAL SHORELINE:

PERMITTING CONSTRUCTION DOCUMENTS

Includes:
Shoreline stabilization
Shoreline plantings
Capping and raising the site
Integrated salt marsh plantings
Drainage infrastructure
Rough grading

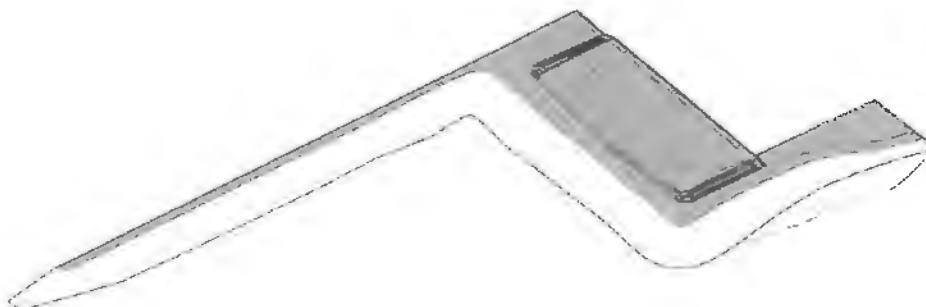

FUTURE PARK ELEMENTS:

CONCEPT DESIGN

Page 8

2.0 SITE ISSUES

2.1 SITE ISSUES EXISTING SITE AND ISSUES



-  **EROSION**
-  **UNDER-PERFORMING ECOLOGY**
-  **SOIL COMPOSITION**
-  **FLOODING + SEA LEVEL RISE**

2.2 SITE ISSUES
SHORELINE CONDITION

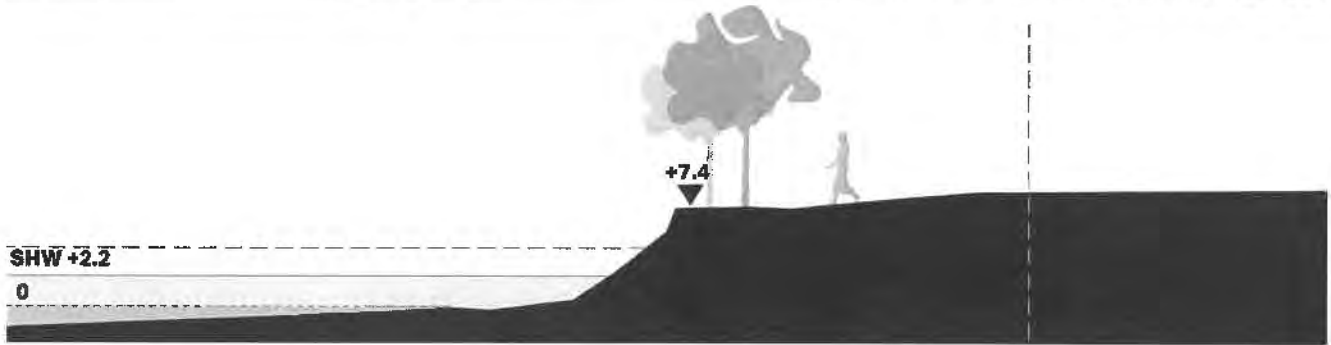

2.3 SITE ISSUES
SITE EROSION



2.4 SITE ISSUES SEA LEVEL RISE



100 YEAR FLOODPLAIN FOR THE 2050'S

ZONE AE

100 year floodplain

ZONE VE

100 year floodplain + wave action

ZONE X FLOOD AREA

500 year floodplain

+12'

FEMA Base Flood Elevation

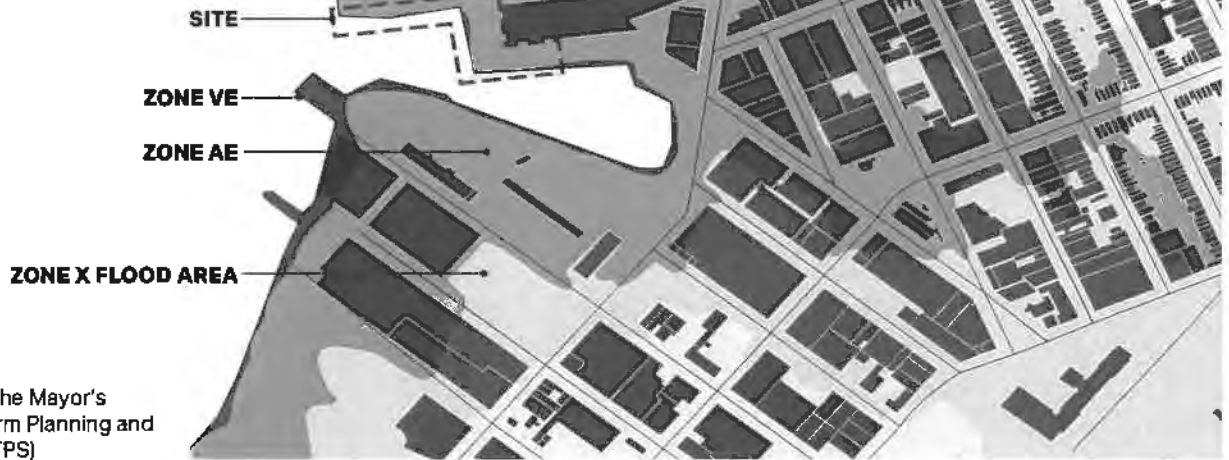

Data provided by the Mayor's
Office of Long-Term Planning and
Sustainability (OLTPS)

3.0 RESPONDING TO THE SITE

3.1 RESPONDING TO THE SITE

-  **ENHANCE ECOLOGICAL BENEFITS**
-  **SOIL COMPOSITION**
-  **STRENGTHEN THE EDGE**
-  **RAISE SITE ELEVATIONS**

3.2 RESPONDING TO THE SITE ENHANCE ECOLOGICAL BENEFITS

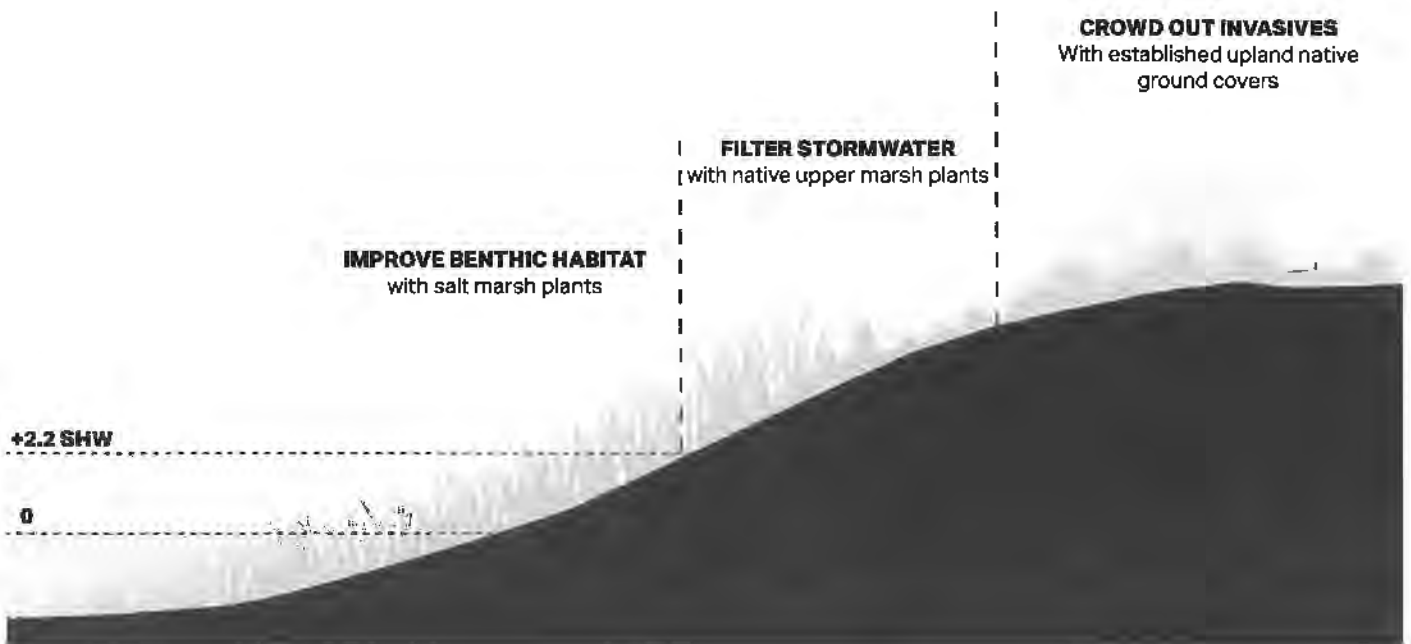

3.3 RESPONDING TO THE SITE SOIL COMPOSITION | CAPPING



NOTE: Environmental testing shows that site is not a brownfield but contains non-hazardous contaminated soils

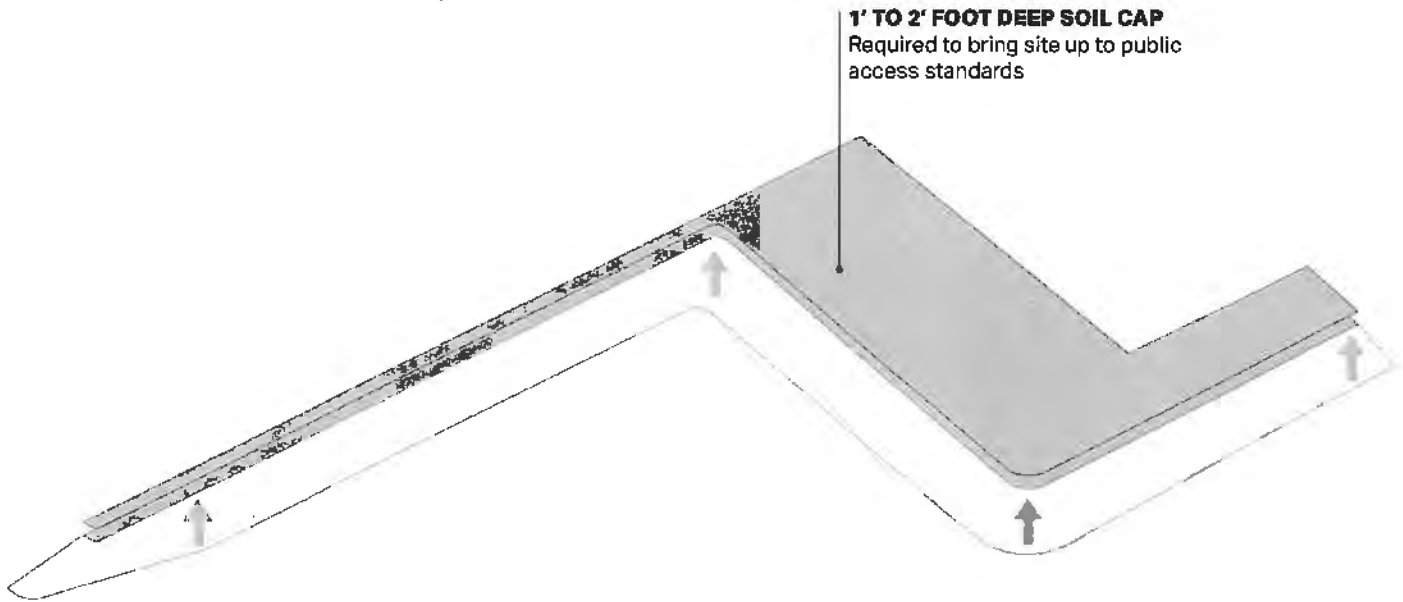

Page 17

3.4 RESPONDING TO THE SITE STRENGTHEN THE EDGE | RIP RAP WITH PLANTING



ARMORED INCLINED EDGE (RIP RAP)

- Long Life Span
- Low Maintenance
- Can be planted for ecological value
- Adjusts easily to minor settlement
- Can resist heavy wave action

Page 18

3.5 RESPONDING TO THE SITE RAISE SITE ELEVATIONS



Elevation +12'

FEMA Base Flood Elevation

Elevation +13'

NYC Building Code Design Flood
Elevation for Museums

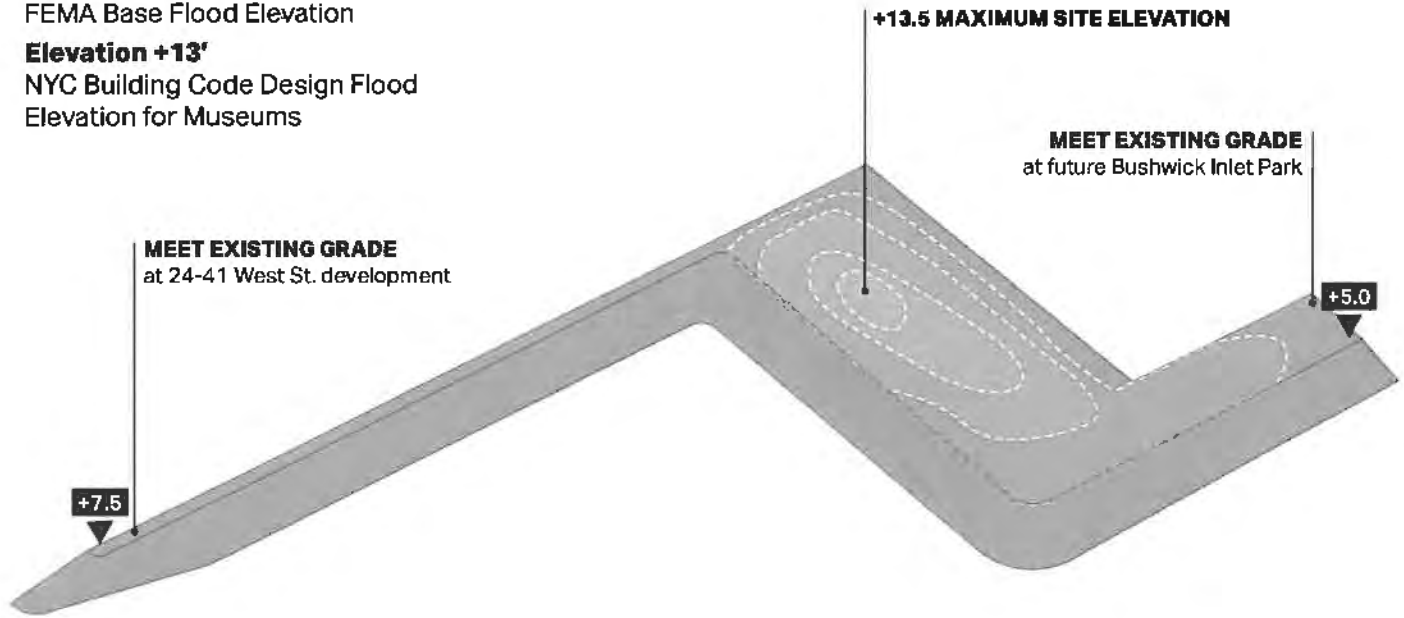

4.0 ECOLOGICAL SHORELINE

4.1 ECOLOGICAL SHORELINE
ECOLOGICAL SHORELINE SITE PLAN

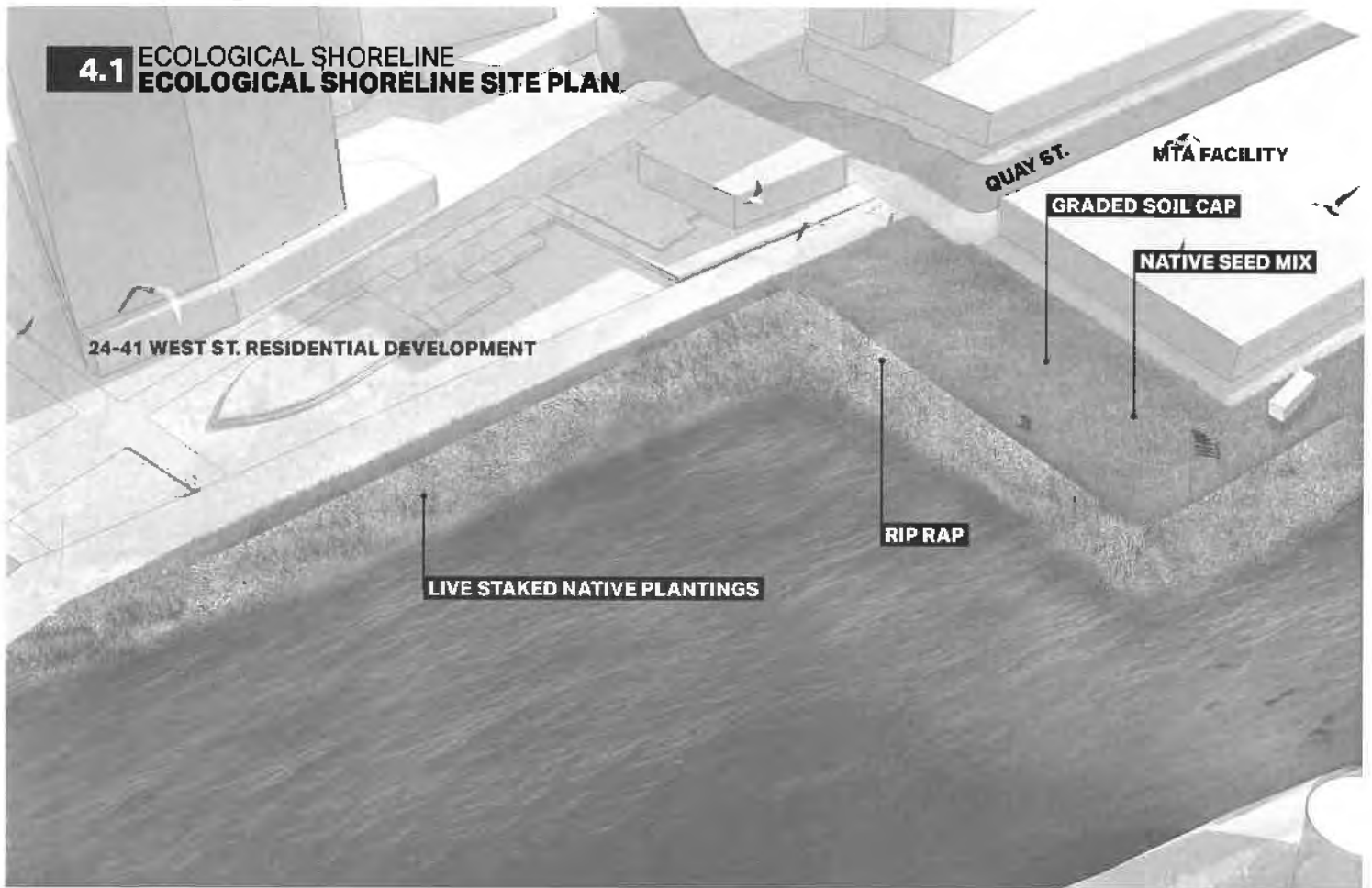

4.2 ECOLOGICAL SHORELINE
SHORELINE EDGE: REINFORCED SHEET PILE TOE

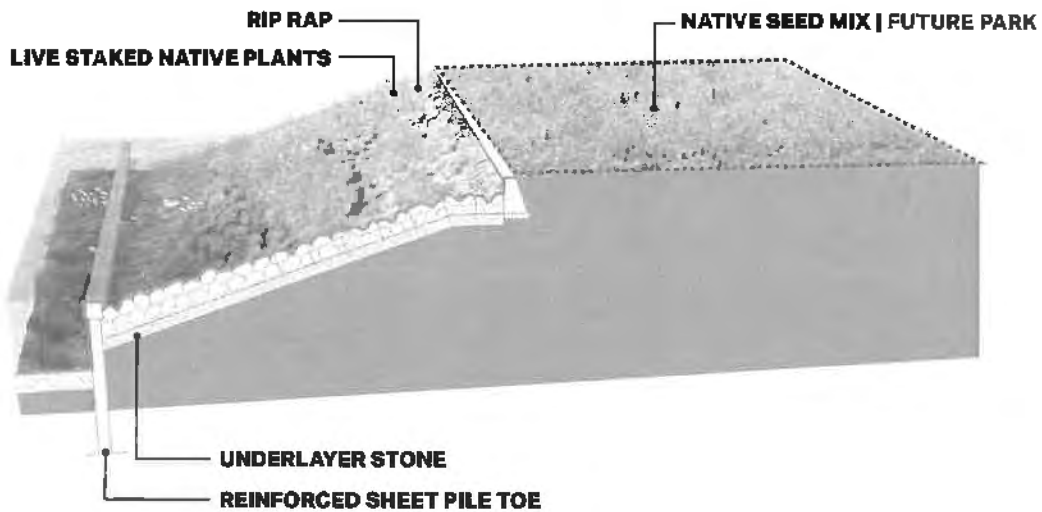

**4.3 ECOLOGICAL SHORELINE
PROPOSED ECOLOGICAL SHORELINE NATIVE PLANTINGS**

KEY PLAN:



TYPICAL LIVE STAKING SECTION:

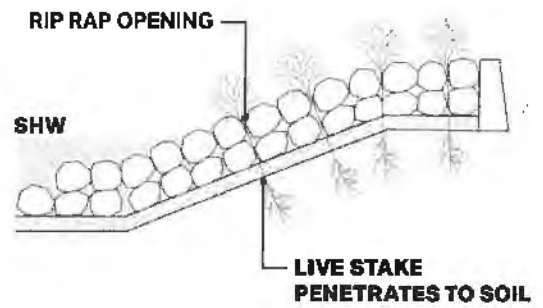

**SMOOTH
CORDGRASS**



MARSH ELDER



WILLOW



**RED OSIER
DOGWOOD**

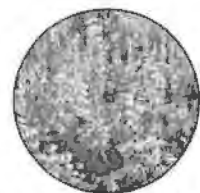

**NATIVE MEADOW
SEED MIX**



5.0 NEXT STEPS

5.1 NEXT STEPS ECOLOGICAL SHORELINE UNDER GCEF GRANT

- Complete GCEF grant activities by July 1st, 2019
- Receive approval of submitted permits (Army Corps of Engineers and NYS Department of Environmental Conservation)
- Finalize Construction Documentation for the Ecological Shoreline

Page 25

5.2 FUTURE ELEMENTS GOALS

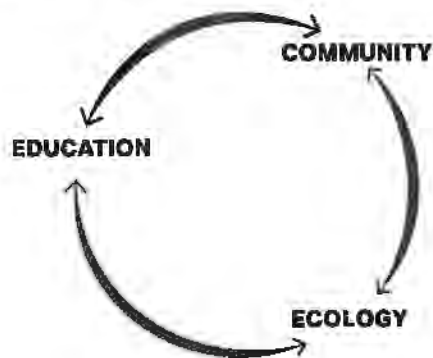

Page 26

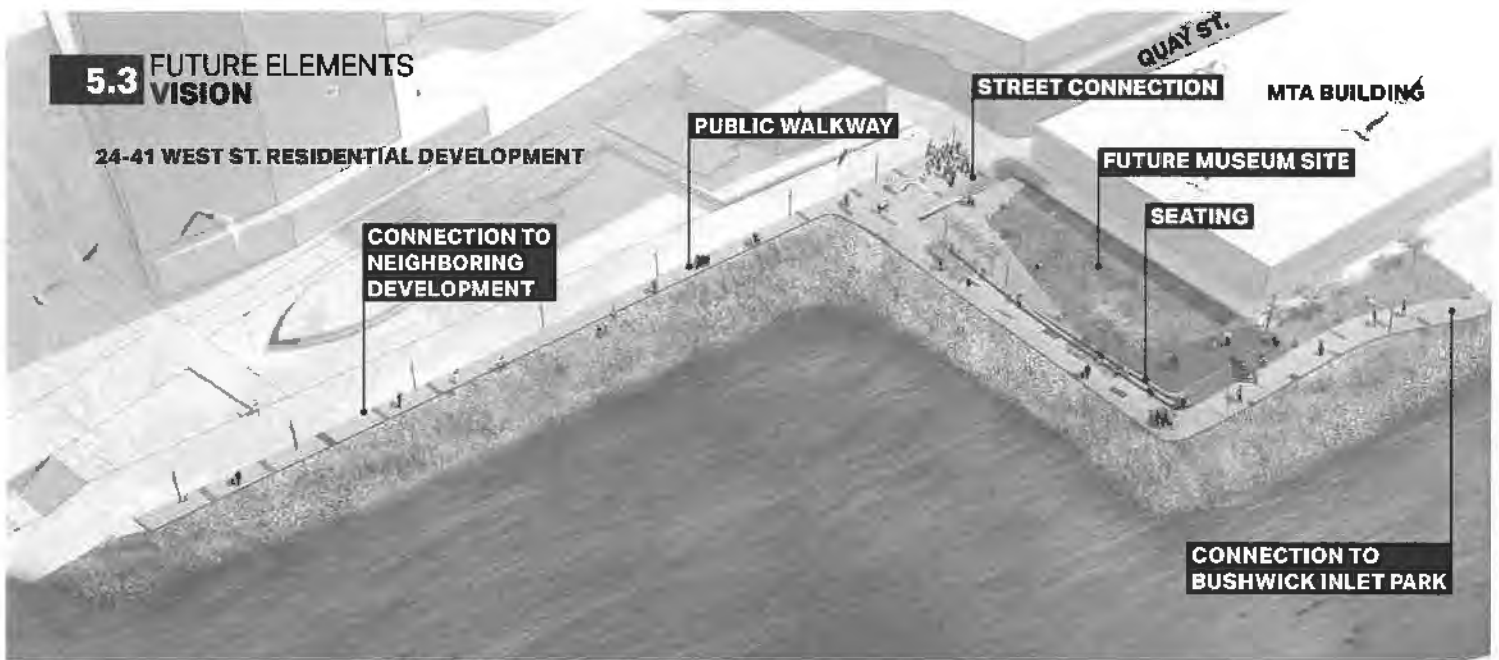

5.4 FUTURE ELEMENTS LONG TERM NEXT STEPS

- **Work with city agencies** on getting the site zoned to allow for a museum and park
- **Continue park design development**
- **Begin design for museum and dock**



MONITOR PARK



GREENPOINT MONITOR MUSEUM



NOAA RESEARCH VESSEL DOCK

THANK YOU!

GreenpointMonitorMuseum.org
GreenpointMonitorMuseum@gmail.com



2019 CB #1 BOARD MEMBER REGULAR MEETING ATTENDANCE REPORT

| Member's Name | 1/8 | 2/12 | 3/12 | 4/9 | 5/14 | 6/11 | 7/9 | 8/13 | 9/10 | 10/10 | 11/12 | 12/10 | Ab's |
|-------------------------------|-----|-----------|------|-----|------|---------|-----|------|------|-------|-------|-------|------|
| Gina Argento (BP) | P | A | P | P | A | A | | | | | | | 3 |
| Bogdan Bachorowski (BP) | P | P | P | P | A | A | | | | | | | 2 |
| Lisa Bamonte (BP) | P | P | P | P | P | P | | | | | | | 0 |
| Louis Barricelli (BP) | P | P | P | A | A | A | | | | | | | 3 |
| Gina Barros (34) | P | A | P | P | P | P | | | | | | | 1 |
| Eric Bruzzatis (34) | P | P | P | P | P | P | | | | | | | 0 |
| Thomas J. Burrows (34) | P | P | P | P | P | P | | | | | | | 0 |
| Iris Cabrera (34) | P | A | P | P | P | P | | | | | | | 1 |
| Philip Caponegro (BP) | P | P | P | P | P | P | | | | | | | 0 |
| Frank P. Carbone (33) | P | P | P | P | P | P | | | | | | | 0 |
| Stephen Chester (33) | P | P | P | P | P | P | | | | | | | 0 |
| Michael Chirichella (BP) | P | A | P | P | P | A | | | | | | | 2 |
| Theresa Cianciotta (33) | P | A | P | P | A | A | | | | | | | 3 |
| Joshua Cohen (BP) | P | P | P | P | P | A | | | | | | | 1 |
| Giovanni D'Amato (34) | | APPOINTED | | | | | P | | | | | | 0 |
| Arthur Dybanowski (33) | P | P | P | P | A | A | | | | | | | 2 |
| T. Willis Elkins (33) | P | P | P | P | P | P | | | | | | | 0 |
| Julia Amanda Foeter (BP) | P | P | P | P | P | P | | | | | | | 0 |
| Samuel Francoz (33) | A | A | A | A | A | REMOVED | | | | | | | 5 |
| Dealice Fuller (BP) | P | P | P | P | P | P | | | | | | | 0 |
| Emily Gallagher (BP) | P | A | P | P | P | P | | | | | | | 1 |
| Vincent Gangone (BP) | P | P | A | P | P | A | | | | | | | 2 |
| Joel Goldstein (33) | | APPOINTED | | | | | A | | | | | | 1 |
| Solomon Green (33) | P | A | A | P | A | A | | | | | | | 4 |
| Joel Gross (BP) | A | A | A | P | A | P | | | | | | | 4 |
| Sonia Iglesias (34) | P | P | P | A | P | P | | | | | | | 1 |
| Moishe Indig (BP) | P | P | P | A | P | P | | | | | | | 1 |
| Bozena Kaminski (BP) | P | A | P | P | P | P | | | | | | | 1 |
| Avrom Katz (33) | P | A | A | A | P | P | | | | | | | 3 |
| William Klagsbald (33) | | APPOINTED | | | | | P | | | | | | 0 |
| Ryan Kuonen (33) | P | A | P | P | P | P | | | | | | | 1 |
| Yoel Landau (BP) | P | A | A | P | P | P | | | | | | | 2 |
| Marie Leanza (34) | P | P | P | P | P | P | | | | | | | 0 |
| Yoel Low (BP) | P | P | A | P | P | A | | | | | | | 2 |
| Trina McKeever (33) | P | P | P | P | A | P | | | | | | | 1 |
| Toby Moskovits (BP) | A | P | P | P | P | A | | | | | | | 2 |
| Martin Needelman (34) | P | P | A | P | A | P | | | | | | | 2 |
| Simon Neustein (33) | A | A | A | A | A | REMOVED | | | | | | | 5 |
| Rabbi David Niederman (BP) | P | P | P | A | P | P | | | | | | | 1 |
| Karen Nieves (34) | P | A | P | P | P | P | | | | | | | 1 |
| Mary Odornirok (33) | P | P | P | P | P | P | | | | | | | 0 |
| Janice Peterson (34) | A | P | P | P | P | A | | | | | | | 2 |
| Dana Rachlin (BP) | P | P | P | P | P | P | | | | | | | 0 |
| Michael Gary Schlesinger (BP) | P | P | P | P | P | P | | | | | | | 0 |
| Isaac Sofer (BP) | A | P | P | P | P | P | | | | | | | 1 |
| Robert Solano (34) | P | P | A | P | P | P | | | | | | | 1 |
| James Stuart (BP) | P | P | P | P | P | P | | | | | | | 0 |
| Del Teague (BP) | A | P | P | P | P | P | | | | | | | 1 |
| Tommy Torres (BP) | P | P | P | P | P | P | | | | | | | 0 |
| Maria Viera (33) | P | P | P | P | P | P | | | | | | | 0 |
| Stephen Weidberg (BP) | P | P | A | P | P | P | | | | | | | 1 |
| Simon Weiser (33) | P | P | A | P | P | P | | | | | | | 1 |
| Tesa Wilson (34) | A | A | A | A | A | REMOVED | | | | | | | 5 |

Tally:

| | JAN | FEB | MAR | APR | MAY | JUN | JUL | AUG | SEP | OCT | NOV | DEC |
|------------------------|-----|-----|-----|-----|-----|-----|-----|-----|-----|-----|-----|-----|
| Present | 42 | 34 | 37 | 42 | 38 | 37 | | | | | | |
| Absent | 8 | 16 | 13 | 8 | 12 | 13 | | | | | | |
| Excused Absence | | | | | | | | | | | | |
| Total | 50 | 50 | 50 | 50 | 50 | 50 | | | | | | |



COMMUNITY BOARD NO. 1

435 GRAHAM AVENUE – BROOKLYN, NY 11211

PHONE: (718) 389-0009

FAX: (718) 389-0098

Email: bk01@cb.nyc.gov

Website: www.nyc.gov/brooklyn1

HON. ERIC L. ADAMS
BROOKLYN BOROUGH PRESIDENT



SIMON WEISER
FIRST VICE-CHAIRMAN

DEL TEAGUE
SECOND VICE-CHAIRPERSON

STEPHEN J. WEIDBERG
THIRD VICE-CHAIRMAN

MARIA VIERA
FINANCIAL SECRETARY

SONIA IGLESIAS
RECORDING SECRETARY

PHILIP A. CAPONEGRO
MEMBER-AT-LARGE

DEALICE FULLER
CHAIRPERSON

GERALD A. ESPOSITO
DISTRICT MANAGER

HON. STEPHEN T. LEVIN
COUNCILMEMBER, 33rd CD

HON. ANTONIO REYNOSO
COUNCILMEMBER, 34th CD

CHAIRPERSON'S CORRESPONDENCE

May 10, 2019-June 7, 2019

| No. | DATE | RECEIVED FROM | SUMMARY | REFERRED TO |
|-----|---------|--|--|---------------------|
| 1 | 5/14/19 | City Planning Commission Department of City Planning 120 Broadway, 31 st Floor New York, NY 10271-3000 | RE: Update on the Department of City Planning's upcoming zoning text amendment to improve the City's resiliency, known as Zoning for Coastal Flood Resiliency. | Teague |
| 2 | 5/20/19 | The Council of New York Honorable Fernando Cabrera Via Email | RE: Executive Budget Increase for Community Boards. | Executive Committee |



COMMUNITY BOARD NO. 1
435 GRAHAM AVENUE – BROOKLYN, NY 11211

PHONE: (718) 389-0009

FAX: (718) 389-0098

Email: bk01@cb.nyc.gov

Website: www.nyc.gov/brooklyncb1

HON. ERIC L. ADAMS
BROOKLYN BOROUGH PRESIDENT



| | | | | |
|---|---------|--|--|--|
| 3 | 5/21/19 | Commissioner Arva R. Rice NYC Equal Employment Practices Commission 253 Broadway Suite 602 New York, NY 10007 | RE: Determination of Compliance for Brooklyn Community Board No.1, Resolution #2019AP/230-471(2019C11 | Executive |
| 4 | 5/31/19 | Metropolitan Realty Exemptions INC. 118 Middleton Street Brooklyn, NY 11206 | RE: Application for Preliminary Certificate of Eligibility for Partial Tax Exemption for 7 Whipple Street. | Land Use, ULURP, & Landmarks (Subcommittee) |



COMMUNITY BOARD NO. 1
435 GRAHAM AVENUE – BROOKLYN, NY 11211

PHONE: (718) 389-0009

FAX: (718) 389-0098

Email: bk01@cb.nyc.gov

Website: www.nyc.gov/brooklyncb1

HON. ERIC L. ADAMS
BROOKLYN BOROUGH PRESIDENT



| | | | | |
|---|---------|--|--|---|
| 5 | 5/31/19 | Intermediate School 318 101 Walton Street Brooklyn, NY 11206 | RE: Sustainability Green Team at I.S. 318. | Environmental Protection, & Education & Youth |
| 6 | 6/3/19 | City Planning Commission Department of City Planning 120 Broadway, 31 st Floor New York, NY 10271-3000 | NYC Department of Housing Preservation & Development RE: Notice of Public Hearing. | Housing & Public Housing |



COMMUNITY BOARD NO. 1
435 GRAHAM AVENUE – BROOKLYN, NY 11211

PHONE: (718) 389-0009

FAX: (718) 389-0098

Email: bk01@cb.nyc.gov

Website: www.nyc.gov/brooklyn1

HON. ERIC L. ADAMS
BROOKLYN BOROUGH PRESIDENT



| | | | | |
|---|--------|--|---|--------------------------|
| 7 | 6/6/19 | Haley Aldrich of New York 1441 Broadway New York, NY 10018 | RE: Record of Decision Fact Sheet for Former NuHart Plastics Manufacturing Site, 49 Dupont Street | Environmental Protection |
|---|--------|--|---|--------------------------|



COMMUNITY BOARD NO. 1
435 GRAHAM AVENUE – BROOKLYN, NY 11211
PHONE: (718) 389-0009
FAX: (718) 389-0098
Email: bk01@cb.nyc.gov
Website: www.nyc.gov/brooklyncb1



HON. ERIC L. ADAMS
BROOKLYN BOROUGH PRESIDENT

SIMON WEISER
FIRST VICE-CHAIRMAN

DEL TEAGUE
SECOND VICE-CHAIRPERSON

STEPHEN J. WEIDBERG
THIRD VICE-CHAIRMAN

MARIA VIERA
FINANCIAL SECRETARY

SONIA IGLESIAS
RECORDING SECRETARY

PHILIP A. CAPONEGRO
MEMBER-AT-LARGE

DEALICE FULLER
CHAIRPERSON

GERALD A. ESPOSITO
DISTRICT MANAGER

HON. STEPHEN T. LEVIN
COUNCILMEMBER, 33rd CD

HON. ANTONIO REYNOSO
COUNCILMEMBER, 34th CD

June 11, 2019

EXECUTIVE COMMITTEE
REPORT

TO: All Board Members
FROM: Dealice Fuller, Chairperson
RE: Executive Committee Meeting held on May 29, 2019
in the CB #1's District Office

The Executive Committee met on Wednesday, May 29, 2019, at 6:30 PM, in the CB #1's District Office at 435 Graham Avenue, Brooklyn, NY 11211 (Corner of Frost Street)/

ATTENDANCE: Present – Fuller (Chair); Weiser; Teague; Weidberg; Viera; Iglesias; Caponegro. Absent – none. (A full quorum was achieved). Also present were board members, members from the public.

The Committee met to organize the agenda for the Board's June 11, 2019 Combined Public Hearing and Board Meeting. The members discussed the various requests and decided the order of the items for the agenda and assigned the time allotments for each.

There were land use items that were placed on the agenda. Due to the timeframe (i.e. - clocks) on the items, it was proposed that the Land Use committee caucus after the presentations made at the public hearing so that a resolution could be formulated to the full board to vote on and meet the clock deadlines.

Chairperson Fuller noted that the agenda would be finalized before any other discussions take place.

Chairperson Ms. Fuller noted the agenda as complete and asked for approval. Mr. Weidberg made a motion to approve the agenda as arranged. Ms. Iglesias seconded the motion. The motion was unanimously carried.

District Manager Mr. Esposito noted that the MTA has moved to market the site where they had washed buses. The site is 40 Quay Street, and a "Request for Proposals" (RFP) was released. He noted that this site was next to the Monitor Museum site, and that there were issues with flooding from the MTA building's roof drains. He noted that the MTA should reach out to the museum.

Ms. Rachlin noted that as a relatively new board member she asked for guidance about what the stance (of the board) is regarding the purchase of the vehicle.

Chairperson Fuller stated that it was a replacement vehicle and the Executive Committee voted in favor of the purchase and the established purchase protocol was followed. She noted that she had asked for any additional suggestions from board members regarding the budget.

In further discussion it was noted that the office's vehicle was a 2002 - Hybrid. The batteries in it have a shelf life. The vehicle was at the end of its useful life. There is an official city process regarding the vehicle. It is turned back to the City.

Ms. Sylla, a member of the public, noted that there is a need at the Pete McGuinness Senior Center to have their kitchen repaired (the hood/range). They cannot make meals. Mr. Esposito asked that they write to the community board so that the board could advocate with the Borough President and elected officials.

It was noted that Council Member Cabrera was looking at a second round of funding for the community boards.

There was a discussion on funding matters.

A timeline regarding the replacement vehicle was distributed. Information of the board's budget balance was distributed. There was a balance of \$3,420.00. A listing of purchases was noted.

Chairperson Fuller said that this was a learning process. She noted that they had discussed what the best uses would be. The funds could not be used for staffing/personnel. It went into OTPS.

Ms. Viera spoke about a participatory process. Suggestions are welcome but must be within the city's restrictions. Chairperson Fuller noted that if future funds were received, she would ask each committee chair to consult with their committee members to make suggestions on how the funds could be utilized.

Ms. Iglesias spoke about issues of affordable housing and the importance of it as a priority in discussions. Mr. Weiser spoke about issues with the post office, street cleaning and double parking.

Mr. Weidberg spoke about considering requests. He noted a request for additional part time staff members.

District Manager Mr. Esposito related that in the past, the office had a Youth Coordinator that was from the Department of Youth Services. There also was a person from CAU that did landlord tenant work.

Ms. Wallin noted that the City should provide the board with updated equipment, computers and programs. In the past, the board had received from the City used computer equipment and poorly functioning programs. The boards are always treated like stepchildren.

Ms. Teague spoke about the recent articles that appeared, and noted that there was a process regarding purchasing the replacement vehicle and that there was nothing illegal about it.

Ms. Iglesias expressed for the members to not be judgmental. It is not you or me but "we".

Ms. Viera reiterated the process for purchasing the replacement vehicle. The purchasing process was reviewed and vetted by the appropriate authorities at the City level. Even the vendor/car dealership used for the purchase was informed by the City.

Mr. Weidberg requested a vote of confidence for the board's staff, and that it be presented to the board. The motion was seconded by Mr. Caponegro. The motion was carried unanimously.

Chairperson Fuller asked that District Manager Mr. Esposito send an email to the members, about the remaining balance of funds in the board's budget, seeking suggestions.

The meeting was concluded.

DF/mbw

Attachment: 1 package

Replacement Vehicle Timeline

- Purchases for a replacement vehicle, upgrade for the Office Alarm System and a large screen TV for the conference room were discussed at the Executive Committee Meeting. We will find out if we are allowed to purchase. If so, the Executive Committee will be polled. (5/30/18).
- New York City Council's Financial Analyst asked if \$ can be used to purchase vehicle (8/2/18).
- New York City Council's Financial Analyst Reply " You can only if it doesn't cross the capital funding threshold, which is an item that cost over \$ 35,000 and will be used for at least five years" (New York City Council, Finance Division 8/2/18).
- Brooklyn Community Board #1 inquiries at Citywide Administrative Services (DCAS) on procedure to purchase a vehicle (8/6/18).
- Executive Committee unanimously approved the purchase of a replacement vehicle, upgrade for the Office Alarm System and a large screen TV for the conference room (8/8/18)
- Citywide Administrative Services (DCAS) reply w/ info on vehicle and deadline "FYI see email thread below" (08/08/18).
- Email forwarded by Citywide Administrative Services (DCAS) from City Worlds Motors LLC, DBA City World Toyota replies, "*2018 model orders can be placed until August 13* (we are telling agencies Aug 10 to give us the extra weekend for a cushion). We can work with agencies as in the past pulling retail inventory from the pipeline but I was thinking we would probably run into an issue with finding inbound units with the BD fleet equipment group" (8/08/18).
- Order typed up and given to the Brooklyn Borough President's Office to Process. (8/9/18).
- Purchase Order for Vehicle accepted by the Financial Management System (FMS), after being processed by the Brooklyn Borough President's Staff (8/14/18).
- Approved order is given to NYC Contracted dealership (8/22/18).
- Vehicle is delivered (12/11/18).
- Brooklyn Borough President Staff sends memo to all Community Boards asking about money, "Our office is conducting a brief survey as to how the City Council \$42K budget allocation is being spent" (3/08/19).
- Reply is sent back that Brooklyn Community Board # 1 has purchased a replacement vehicle, upgraded the office alarm system, a large screen TV" for the conference room (3/08/19).

*All requirement contract purchases are subject to approval by New York City Comptroller's Office.

- Vehicle: 2018 Model Rav4 Hybrid LE Super white 0040 (NYC DCAS R/C 3687186 Registration 20161201651 Item 1) Price: \$25,994.80
- Router: Linksys EA9500 Wireless Router 802. 11 a/b/g/ ac-desktop Price: \$377.97 (upgrade per DOITT recommendation)
- Alarm System Upgrade: Security System Upgrade , 1 ADEMCO Vista 20 P 8-48 Zone Panel, Battery, Siren, Price: \$199.00, 2 ADEMCO 6160 Alpha English Key pad (Night Time Back Light) (Zone Descriptions), Price: \$ 198.00, 2 HIK HD Camera 1080P EXIR Turret Network Camera, Price: \$ 500.00, 1 HIK DVR DS-7604, Price: \$399.00, 1 Embedded Plug & Play CCTV 20" Camera Monitor HD System Monitor, Price : \$279.00, Upgrade/ Install New Camera and Alarm System, Install 1 New HD Monitor, Price \$ 795.00, Total: \$2,370
- Flat Panel TV 56" to 1 for Conference Room: Manufacturer: SONY TV, Price: \$1799.91, Model: 15-DA0076NR, Product: Touch Notebook Manufacturer: HP, Price: \$449.00 Flat Panel TV Install Manufacturer: P.C RICHARD, Price: \$299.00 Model: VPC175 PRODUCT; Service Contract: Major Manufacturer R: PC. RICHARD, Price: \$749.99, MODEL 9390GT3, PRODUCT : TV WALL BRACKET Manufacturer: Generations, Price: \$ 99.00, Model: SOUNDBAR500bB, Product : Sound Bar, Manufacturer : Bose, Price: \$ 499.91, Model: INSSOUND BAR, Product: Audio/Video Installati Manufacturer: P.C. Richard, Price: \$ 79.00 Total: \$ 3,977.79
- 2020 Pocket Calendars: Quantity 150 , Color Red & 100 Colossal Tote Bags Price: \$707.43 (for November Board member distribution)
- 4 HP Computers HP EliteDesk 800 G4 SFF Business PC Price: / 4X917.48= \$3669.92 /4 3MW60AV Technical Labels - Intel 8th Gen Core i7 vPro Label 4 F0G76AA Project Man , 4 New! HP Pro Display P232 23-inch Monitor K7X31AA#ABA Warranty - Protected by HP 3-year parts, 3-year labor 3-year onsite limited warranty Exchange available Price \$87.00 each/ 4 X 87.00= \$348.00 / 4 UE334E HP 5 year Next Business Day Onsite Hardware Support w/Defective Media Retention for Desktops, HP LCD Speaker Bar \$18.81 each 4X 18.81= \$75.24 HP 5y Nbd/ Disk Retention DT only SVC, Price: \$ 34.27 each 4 X 34.27 = \$137.08 / 4 NQ576AT Total: \$4,115.64 (per NYC DOITT recommendation)
- Postmaster Postage, Price: \$ 2,000

Total: \$ 39,543.63

BUDGET BALANCE
FY 2019

| | | |
|---------------------------------------|---------------|-------------------------|
| NYC Council restricted O.T.P.S | | \$956.37 |
| Code | 100 | \$2123.29 |
| Code | 300 | \$300.00 |
| Code | 105 | \$40.90 |
| | Total: | <u>\$3420.56</u> |



COMMUNITY BOARD NO. 1

435 GRAHAM AVENUE – BROOKLYN, NY 11211

PHONE: (718) 389-0009

FAX: (718) 389-0098

Email: bk01@cb.nyc.gov

Website: www.nyc.gov/brooklyn1

HON. ERIC L. ADAMS
BROOKLYN BOROUGH PRESIDENT



SDMON WEISER
FIRST VICE-CHAIRMAN

DEL TEAGUE
SECOND VICE-CHAIRPERSON

STEPHEN J. WEIDBERG
THIRD VICE-CHAIRMAN

MARIA VIEIRA
FINANCIAL SECRETARY

SONIA IGLESIAS
RECORDING SECRETARY

PHILIP A. CAPONEGRO
MEMBER-AT-LARGE

DEALICE FULLER
CHAIRPERSON

GERALD A. ESPOSITO
DISTRICT MANAGER

HON. STEPHEN T. LEVIN
COUNCILMEMBER, 33rd CD

HON. ANTONIO REYNOSO
COUNCILMEMBER, 34th CD

June 11, 2019

COMMITTEE REPORT

TO: Chairperson Dealice Fuller
and CB#1 Board Members

FROM: Mr. Thomas J. Burrows, Committee Chair
SLA Review & DCA Committee

RE: Committee Report

The SLA Review & DCA Committee met on Tuesday, May 28, 2019, at 6:30 PM, in the CB #1's District Office, 435 Graham Avenue, Brooklyn, NY 11211.

ATTENDANCE: Present – Burrows; Barros; Bruzaitis; Dybanowski; Cohen; Foster; Solano; Stuart; Torres. Absent – Bachorowski; Sofer. (A quorum was present). Also present was Vice Chairperson Mr. Weiser.

It is noted that all applicants are requested to sign stipulations.

AGENDA

I. UNENCLOSED SIDEWALK CAFES:

UNENCLOSED SIDEWALK CAFE: BERNIE'S POINT, 836 LORIMER STREET, APPLICATION #2998-2019-ASWC; 8 Tables; 16 Chairs, NEW. (Rep./Michael Kelly)
The Committee recommends approval.

UNENCLOSED SIDEWALK CAFÉ: WINSOME FOODS, LLC, DBA WIN SON, 159 GRAHAM AVENUE (#2019157-DC); 19 Tables; 38 Chairs. RENEWAL. (Rep./ Joshua Ku, Managing Member)
The Committee recommends approval.

UNENCLOSED SIDEWALK CAFÉ: 451 GRAHAM AVENUE CORP., DBA THE RICHARDSON, 451 GRAHAM AVENUE, (#1314137 – DCA); 15 Tables, 30 Chairs. RENEWAL. (Rep./Joel Kulp, President)
The Committee recommends approval.

UNENCLOSED SIDEWALK CAFÉ: 600 METROPOLITAN CORP., DBA ALLIGATOR LOUNGE, 600 METROPOLITAN AVENUE (#1311871 – DCA); 6 Tables, 18 Chairs (Rep./John McGillion, President)
The Committee recommends denial. The applicant has violated the DCA regulations regarding unenclosed sidewalk cafés.

UNENCLOSED SIDEWALK CAFÉ: D&D CAFÉ LLC, 128 MESEROLE STREET, BROOKLYN, NY 11206-2070, APPLICATION # 454-2019 ASWC; 19 Tables; 38 Chairs, NEW. (Rep./Shlomo Steve Wygoda, SWA Architecture PLLC)
The Committee recommends denial unless applicant reappears.

II. LIQUOR LICENSES:

NEW:

1. 82 S4th Restaurant & Café, dba Casa Imelda, 82 South 4th Street, (Alteration, liquor, wine/beer)
The Committee recommends denial.
2. 104 South 4TH Inc., dba Randolph Beer, 104 South 4th Street, (Class Change, liquor, wine/beer, cider, rest, brewer)
The Committee recommends denial.
3. 147 149 McCarren LLC., dba McCarren Hotel, 160 N. 12th Street, (Alteration, Method of Operation Change, liquor, wine/beer, cider, hotel)
The Committee recommends approval with the proviso that the applicant resubmit a revised application.
4. 462 Union Avenue Bar LLC., dba Macri Park, 462 Union Avenue, (Corporate Change, liquor, wine/beer, cider, bar/tavern) – POSTPONED.
5. AL Sushi NY INC. dba Mizu Sushi, 311 Bedford Avenue, (New, wine/beer, cider, rest)
Applicant did not appear. The Committee recommends denial.
6. Anaya Alam LLC, 318 Bedford Avenue, (New, wine/beer, cider, bar/tavern) – POSTPONED.
Applicant/owner, is to appear at the next meeting of the committee.
7. Bernie's Point LLC, dba Bernie's, 836 Lorimer Street, (Alteration, liquor, wine/beer, cider, rest)
The Committee recommends approval.

8. Domino Park F & B Management LLC, dba Tacocina, 292 Kent Avenue, (Method of Operations Change, liquor, wine/beer, cider, rest)
The Committee recommends approval, pending a letter from the park/property owner [Two Trees] and stipulations regarding the hours of operation.

9. Indigo Williamsburg HM LLC., dba TBD, 500 Metropolitan Avenue, (New, liquor, wine/beer, cider, Hotel)
The Committee recommends approval. A revised application is to be submitted. Landscaping is to be provided.

10. Juicerie IV LLC, dba The Butcher's Daughter, 271 Metropolitan Avenue, (Alteration, liquor wine/beer, cider, rest)
The Committee recommends approval.

11. La Guira Restaurant Corp., 580 Broadway, (New, liquor, wine/beer, cider, bar/tavern) –
POSTPONED.

12. Michael Braman or Entity to be formed, 774 Driggs Avenue, (New, WINE/BEER, cider, rest)
Applicant did not appear. The Committee recommends denial.

13. Original Music Workshop Inc. & The Middle LLC., dba National Sawdust OMW, 80 North 6th Street, (Alteration, liquor, wine/beer, cider, rest)
The Committee recommends approval.

14. Ozi Dumplings, dba Ozi Dumplings, 19 Bogart Street, Unit 1, (New, WINE/BEER, cider, rest)
The Committee recommends approval.

15. Pomp and Circumstance LLC, dba Pomp and Circumstance, 577 Lorimer Street, (New, liquor, wine/beer, cider, rest)
The Committee recommends approval.

16. Secret Loft LLC., dba Secret Loft, 90 Scott Avenue, (New, liquor, wine/beer, cider, bar, tavern)
POSTPONED, The Committee requests that they present to the full board at the June 11, 2019 meeting because they indicate having over 250 patrons.

The Committee is also requesting a letter to be sent to the NYC Night Life Mayor and NYPD requesting that this area of East Williamsburg be reviewed because there are a number of these late night venues within close proximity. There are public safety concerns with the crowds of people, traffic congestion and patrons traversing through the industrial area's streets and train tracks.

17 TLP Brooklyn LLC, iOLO, 485 Lorimer Street, (New, liquor, wine/beer, cider, rest)
The Committee recommends approval.

RENEWALS:

1. 89 Conselyea Realty LLC., dba DeStefanos Steakhouse, 89 Conselyea Street, (Renewal, liquor, wine/beer, cider)

2. 170 Bedford Restaurant LLC, dba The Meatball Shop, 170 Bedford Avenue, (Renewal, liquor wine/beer, cider, rest)
3. Aleyin LLC., dba Café Beit, 158 Bedford Avenue, (Renewal, wine/beer, cider, bar, tavern)
4. Avago Corp., dba Berry Park, 4-6 Berry Street, (Renewal, liquor, wine/beer, cider, bar, tavern)
5. Avant Gardner LLC., dba Avant Gardner, The Great Hall, The Kings Hall, and The Brooklyn Mirage, 111 Gardner Avenue and 140 Stewart Avenue (Renewal, liquor, wine/beer, cider, multipurpose event center/venue) – The Committee recommends denial. *
6. Black Rabbit Bar LLC., dba Black Rabbit, 91 Greenpoint Avenue, (Renewal, liquor, wine/beer, cider, bar/tavern)
7. Bridge 109 Corp, dba Gordon Bennett, 109 South 6th Street, (Renewal, liquor, wine/beer, cider, rest)
8. Boogaloo Bar Inc. dba Duff's Brooklyn, 168 Marcy Avenue, (Renewal, liquor, wine/beer, cider, bar/tavern)
9. Brooklyn Bowl LLC, 61-77 Wythe Avenue, (Renewal, liquor, wine/beer, cider, rest)
10. Campbell Sister LLC, dba Campbell Cheese and Grocery, 502 Lorimer Street, (Renewal, wine/beer, cider)
11. Carrie's Hospitality LLC, dba Elder Greene, 160 Franklin Street, (Renewal, liquor, wine/beer, cider, bar/tavern)
12. Cervceria Havemeyer LLC, dba Cervceria Havemeyer, 149 Havemeyer Street Store #3, (Renewal, liquor, wine/beer, cider, rest)
13. Coyocan Lorimer LLC, dba Zona Rosa, 571 Lorimer Street, (Renewal, liquor, wine/beer, cider, rest)
14. Davis and Devoe Group LLC, dba Teddy's Bar & Grill, 96 Berry Street, (Renewal, liquor, wine/beer, cider, rest)
15. Dingxiang Inc., dba Birds of Feather, 191 Grand Street, (Renewal, wine/beer, cider, rest)
16. Double Deep LLC., dba Black Flamingo, 168 Borinquen Place - Store S5, (Renewal, liquor, wine/beer, cider, rest)
17. Isleworth Management LLC, dba New Z & J Wine & Liquor, 761 Manhattan Avenue, (Renewal, liquor, wine/beer, cider) *This is a liquor Store. ***
18. Hinomaru Kitchen Inc., dba Ryujin Ramen, 513 Grand Street, (Renewal, wine/beer, cider, rest)
19. Los Cuantes LLC, dba Rosario, 168 170 Wythe Avenue, (Renewal, liquor, wine/beer, cider, rest)
20. Ott Bagel Inc., 970 Manhattan Avenue, (Renewal, wine/beer, cider, rest)
21. Our Wicked Lady LLC., dba Our Wicked Lady, 153 Morgan Avenue, (Renewal, liquor, wine/beer, cider, bar, tavern)
22. Polmost Food Corp, dba Associated, 802 Manhattan Avenue, (Renewal, beer/cider, supermarket). *This is grocery store. ***
23. Red House BK LLC, dba Kings County Imperial, 20 Skillman Avenue, (Renewal, liquor, wine/beer, cider, rest)
24. Sterling Caterers Inc., dba Ateres Avrohom, 75 Ross Street, (Renewal, liquor, wine/beer, cider)
25. WoodFoot LLC, dba Pokito, 155 South Street, Store #2, (Renewal, liquor, wine/beer, cider, rest)
26. Yurit S. Munoz and Eugenio Zenteno, dba Acapulco Restaurant Deli; 1116 Manhattan Avenue, (Renewal, beer, cider, rest)

The Committee recommends approval of the renewal licenses with the exception of:

* (#5.) - Avant Gardner LLC., dba Avant Gardner, The Great Hall, The Kings Hall, and The Brooklyn Mirage. This application is recommended for denial.

** (#17. & #22.) – [Isleworth Management LLC, dba New Z & J Wine & Liquor; Polmost Food Corp, dba Associated] - These two listings are not for any on premises licenses and were not reviewed.

III. PREVIOUSLY POSTPONED ITEMS:

The Black Squirrel Crew LLC, 25-29 Thames Street, (New, wine/beer, cider, bar)
The Committee recommends approval.

The next meeting of the SLA Review & DCA Committee is:

WHEN: Tuesday June 25, 2019
TIME: 6:30 PM
WHERE: CB#1's District Office
435 Graham Avenue
Brooklyn, New York 11211
(Corner of Frost Street)



COMMUNITY BOARD NO. 1
435 GRAHAM AVENUE – BROOKLYN, NY 11211

PHONE: (718) 389-0009

FAX: (718) 389-0098

Email: bk01@cb.nyc.gov

Website: www.nyc.gov/brooklyn1

HON. ERIC L. ADAMS
BROOKLYN BOROUGH PRESIDENT



SIMON WEISER
FIRST VICE-CHAIRMAN

DEL TEAGUE
SECOND VICE-CHAIRPERSON

STEPHEN J. WEIDBERG
THIRD VICE-CHAIRMAN

MARIA VIERA
FINANCIAL SECRETARY

SONIA IGLESIAS
RECORDING SECRETARY

PHILIP A. CAPONEGRO
MEMBER-AT-LARGE

DEALICE FULLER
CHAIRPERSON

GERALD A. ESPOSITO
DISTRICT MANAGER

HON. STEPHEN T. LEVIN
COUNCILMEMBER, 33rd CD

HON. ANTONIO REYNOSO
COUNCILMEMBER, 34th CD

June 11, 2019

COMMITTEE REPORT

TO: Chairperson Dealice Fuller
and CB#1 Board Members

FROM: Del Teague, Committee Chair
Land Use, ULURP & Landmarks [subcommittee] Committee

RE: Committee Meeting Held on June 3, 2019

The Committee met on Monday, June 3, 2019, at 6:30 PM, at the CB#1's District Office, 435 Graham Avenue, Brooklyn, NY 11211 (Corner of Frost Street).

ATTENDANCE: Present - Teague; McKeever; Barros; Chesler; Rabbi Niederman; Nieves; Sofer; Weidberg; Weiser. Absent – Viera; Kaminski. (A quorum was present)

AGENDA

-1- BSA APPLICATION FOR 115 BROADWAY, BLOCK 2471 LOT 13 -

Mr. Ben Stark presented. This is an application for a variance to develop a six story plus mezzanine mixed use building on the triangular shaped lot at 115 Broadway. There was a strong showing of residents at the meeting expressing concern about the 102foot height of the proposed development, which the residents argued would tower over the adjacent buildings and would alter the essential character of the area.

It was also noted that the customers of the ground floor tenant (expected to be a café) would likely use the tiny, adjacent public plaza as a de facto outdoor café, thus enabling the tenant to function as if it had an outdoor café without the responsibility of getting a permit and maintaining the plaza.

In addition, the committee listened to the concerns that the variance might not be the minimal variance required and that the hardship was self-created. The committee members discussed the need for the BSA to conduct due diligence regarding the reasonable price to have paid for the lot based on a zoning per square foot cost.

Recommendation: After much discussion the committee voted [6 in favor, 1 opposed, 2 abstentions] to recommend -1- approval of (a) the request for waiver of ZR 23-32 (minimal lot area for residences), and (b) ZRs 35-31 and 23-153 (maximum floor area ratio for Quality Housing building);

-2- approval in part of the request for waiver of ZRs 35-31 and 33-122 (maximum total floor area ratio for mixed use building) on the condition that the developer bring the height of the building from 102 feet, 2 inches down to 86 feet (70 feet from ground to roof, plus 16 feet for the bulkhead); and

-3- denial of the request for waiver of ZRs 35-652 and 23-662 (maximum base height, maximum total height, and required setbacks for mixed use building).

In sum, the committee recommends denying that part of the variance that would allow the requested height of 102 feet, but not opposing allowance of a development on the site, if the total height is reduced to 70 feet to the roof, plus a 16 foot bulkhead. In addition the committee voted to condition the approvals on the requirement that the applicant communicate with DOT regarding taking over maintenance of the plaza and agree to refrain from having a bar on the ground floor.

-2- BRIEFING-BSA APPLICATION FILED FOR 19 MASPETH AVENUE (AKA 220 CONSELYEA STREET) -

Mr. Ben Stark presented a briefing on an application for a use waiver to allow a residential development on another triangular lot in a C8-2 district where no residential development is allowed as of right. The development would consist of conforming commercial space on the ground floor, and 15 residential units on the upper 4 floors. The overall height of the building would be 60 feet to the roof, plus a 16-foot bulkhead. Since this lot is a corner lot, the developer is not required to have setbacks. The zoning across the street is R6A.

The applicant was not ready to present a completed package. However, the application is already on the 60-day clock. Mr. Stark will try to get written permission from BSA to hold off on a hearing, so that we can delay our vote until after the summer recess. If he is not able to get BSA's permission, the full board will have to vote at our June meeting.

-3- BRIEFING- POTENTIAL APPLICATION TO REZONE SMALL AREA FROM C8-2 AND R6B/C2-4 to R7A/C2-4 TO ENABLE RESIDENTIAL MIH DEVELOPMENT AT 824 METROPOLITAN AVENUE -

This application does not have to be voted on yet; the applicant assured us it is months away from being certified. The proposed development will be an 8-story building with 36 dwelling units- 11 affordable. The abutting lot and block across the street are zoned for residential use.

The ground floor and cellar will be used commercially. The applicant is talking to St. Nicks Alliance regarding marketing the affordable units.

**-4 SPECIAL PERMIT – N190327 CMK, N190258 CMK & N190626 CMK – 77
COMMERCIAL STREET - SUBMITTED BY WATERVIEW AT GREENPOINT LLC:**

requesting the first three-year renewal of the previously approved special permit and authorizations. The item is not subject to Uniform Land Use Review Procedure (ULURP) and does not require a public hearing by the Community Board or City Planning Commission, however, if the board has any comments or recommendations on the application, they are to be sent by July 15, 2019 to the City Planning Commission.

The board has previously reviewed this item and voted on it in 2013. The recommendation was to disapprove with Modifications/Conditions. This recommendation is attached.



Community/Borough Board Recommendation
Pursuant to the Uniform Land Use Review Procedure

| | |
|------------------------------------|---|
| Application #: C 140047 ZBK | Project Name: 77 Commercial Street |
| CEQR Number: 14DCPD10K | Borough(s): Brooklyn Community District Number(s): 1 |

Please use the above application number on all correspondence concerning this application

SUBMISSION INSTRUCTIONS

- Complete this form and return to the Department of City Planning by one of the following options:
 - EMAIL (recommended):** Send email to CalendarOffice@planning.nyc.gov and include the following subject line: (CB or BP) Recommendation + (8-digit application number), e.g., 'CB Recommendation #C1000002SQ'
 - MAIL:** Calendar Information Office, City Planning Commission, Room 2E, 22 Reade Street, New York, NY 10007
 - FAX:** (212) 720-3356 and note 'Attention of the Calendar Office'
- Send one copy of the completed form with any attachments to the applicant's representative at the address listed below, one copy to the Borough President, and one copy to the Borough Board, when applicable.

DocId: Description:

13 APR 6 1:18 PM

IN THE MATTER OF an application submitted by Waterview at Greenpoint LLC pursuant to Sections 197-c and 201 of the New York City Charter for the grant of a special permit pursuant to Section 62-83b of the Zoning Resolution to modify the height and setback requirements of Section 62-34 (Developments on land and platforms) and Section 62-354 (Special height and setback regulations) in connection with a proposed mixed-use development on property located at 77 Commercial Street (Block 2472, Lot 410), in R6 and R6/C2-4 Districts, Borough of Brooklyn, Community District 1.

Plans for this proposal are on file with the City Planning Commission and may be seen in Room 3N, 22 Reade Street, New York, N.Y. 10007.

| | | | |
|---|--|--|-------------------------------|
| Applicant(s): Waterview at Greenpoint LLC 4871 12th Avenue, Suite 11 Brooklyn, NY 11219 | | Applicant's Representative: Jay A. Segal Greenberg Traurig, LLP 200 Park Avenue New York, NY 10168 | |
| Recommendation submitted by: Brooklyn Community Board 1 | | | |
| Date of public hearing: Aug. -20, 2013 | | Location: Automotive BS 50 Bedford Avenue, Bklyn, NY 11222 | |
| Was a quorum present? YES <input checked="" type="checkbox"/> NO <input checked="" type="checkbox"/> | | <small>A public hearing requires a quorum of 20% of the appointed members of the board, but in no event fewer than seven such members.</small> | |
| Date of Vote: Sept. 9, 2013 | | Location: Swinging 60's Senior Center 211 Ainslie Street, Bklyn, NY 11211 | |
| RECOMMENDATION <input checked="" type="checkbox"/> Approve <input type="checkbox"/> Disapprove <input type="checkbox"/> Approve With Modifications/Conditions <input checked="" type="checkbox"/> Disapprove With Modifications/Conditions | | | |
| <small>Please attach any further explanation of the recommendation on additional sheets, as necessary.</small> SEE ATTACHED REPORT | | | |
| Voting # In Favor: 29 # Against: 9 # Abstaining: 0 | | Total members appointed to the board: 50 | |
| Name of CB/BB officer completing this form | | Title CHAIRMAN | Date SEPT. 10, 2013 |

CHRISTOPHER H. WOJCIECHOWSKI



COMMUNITY BOARD No. 1

435 GRAHAM AVENUE - BROOKLYN, N.Y. 11211-2429

PHONE: (718) 389-0009

FAX: (718) 389-0098

Email: bk01@cb.nyc.gov

Website: www.nyc.gov/brooklyncb1

HON. MARTY MARSHOWITZ
BROOKLYN BOROUGH PRESIDENT



DAVID JOSEPH WISER
FIRST VICE-CHAIRMAN

CHRISTOPHER H. OLECHOWSKI
CHAIRMAN

HON. STEPHEN Y. LSVAN
COUNCILMEMBER, 34th CD

DEL TEAGUE
SECOND VICE-CHAIRPERSON

GERALD A. DEPOSITO
DISTRICT MANAGER

HON. DIANA RYDINA
COUNCILMEMBER, 34th CD

STEPHEN J. HENDERSON
TRAVELER-COMMUNITY

DEBRAE POLLOCK
FINANCIAL SECRETARY

ISRAEL ROSENBERG
RECORDS SECRETARY

PHILIP A. GURDOLSKO
MEMBER-AT-LARGE

August 28, 2013

COMMITTEE REPORT

TO: Chairman Christopher H. Olechowski and
CB #1 Board Members

FROM: Del Teague, Committee Chair
Land Use, ULURP and Landmarks (subcom.) Committee

RE: CB #1 Land Use, ULURP and Landmarks (subcom.) Committee
Recommendations For 77 Commercial Street and
Greenpoint Landing Proposals

On December 6, 2004 Brooklyn Community Board No. 1 opposed The NYC Department of City Planning's 2005 Rezoning proposal when it conducted its review. The board noted in its report that "...these areas of our community were in need of rezoning, but that the Department of City Planning's rezoning proposal did not meet the Community's needs."

The Board recognized that the rezoning plan did not adequately address the vital issues of economic development, affordable housing, parks, open space, building height and bulk.

In addition, The Points of Agreement adopted by both the City Council and the Mayor's Office were conceived without Community Board #1's input. These points were never consummated. Promises made on May 1, 2005 regarding affordable housing were never delivered and parks were never built.

We are now being asked to review the two remaining large tracts of property that complete the assemblage of our waterfront.

We must again say "Disapprove" (with modifications/conditions) to the Administration's attempt to plan for our community and not with our community.

L. 77 COMMERCIAL STREET - City Planning (Application # C 140047 ZSK) - 77 Commercial Street: In the matter of an application submitted by Waherview at Greenpoint LLC pursuant to Sections 197-c and 201 of the New York City Charter for the grant of a special permit pursuant to Section 62-836 of the Zoning Resolution to modify the height and setback requirements of Section 62-341 (Developments on land and platforms) and Section 62-354 (Special height and setback regulations) in connection with a proposed mixed-use development on property located at 77 Commercial Street (Block 2472, Lot 410), in R6 and R6/C2-4 Districts, Borough of Brooklyn, Community District 1.

RESOLUTION: DISAPPROVE WITH MODIFICATIONS/CONDITIONS

The committee recommends disapproval unless the following conditions are met:

1.) Affordable Housing - The developer must provide a wider range of unit sizes and eligibility by adjusting the proposed sizes of the apartments and lowering the AMI percentages as follows:

- Carve out of affordable units - at least 70 units of the affordable housing be specifically earmarked for senior citizens/disabled, 30% AMI and lower, utilizing senior housing funding from HUD Section 202/Section 8 programs (this funding source prefers smaller units for seniors, i.e. more studios, allowing for more housing units to be constructed).

- The balance of the units are to be developed as follows:

| | |
|-----|------------------------|
| 30% | studio apartments |
| 35% | 1 - bedroom apartments |
| 30% | 2 - bedroom apartments |
| 5% | 3 - bedroom apartments |

with the following income breakdowns:

| | |
|-----|--------------------------|
| 60% | of the units for 40% AMI |
| 20% | of the units for 50% AMI |
| 20% | of the units for 60% AMI |

The number of units might deviate from 200, either up or down, by this recommended unit distribution (including elderly units), though the 165,000 sq. ft. of affordable housing would remain.

2.) The Developer must avail itself to other programs and funding sources that would make the proposed units more affordable with a lower AMI (programs such as HDC's LAMP, as well as NYS HCR's 80/20, bonds and tax credits). If necessary, some portion or all of the \$7million allocated for the park must be used to meet this affordability mandate. Other funding sources could be discretionary funding from the Council Member and Brooklyn Borough President. The developer should apply for funding before deadlines expire to achieve the community's desired AMI. The developer should avail itself to NYS HCR's announced pre-registration workshops in NYC on September 10, 2013 and meet deadlines for funding of applications (October 10, 2013).

3.) Special Permit Bulk Text - shall be conditioned on the filing of an Inclusionary Housing Plan for the developer's site to its maximum 2.75 FAR - and that as opposed to the Zoning resolution's 80% AMI allowance, such units shall not exceed 60% AMI.

4.) Reservation of units for Community Preference - At the minimum, 50% of community preference for the lottery should result in CB #1 residents, including displaced former residents since the 2005 rezoning was adopted, and be prioritized to obtain the lowest AMI (40%-60% AMI).

5.) On the basis of respecting the developer's economics, there is no reason why stories 1-6 in all three buildings cannot integrate the affordable units and market rate units. Affordable units are to be integrated below the 7th floor in the tower or market rate parts of the proposed development.

6.) We also insist that the costs for amenities (including parking) are to be discounted for residents of the affordable units.

7.) All of the money donated by the developer for the park will be earmarked for this park and not placed into the City's General Fund.



COMMUNITY BOARD NO. 1

435 GRAHAM AVENUE – BROOKLYN, NY 11211

PHONE: (718) 389-0009

FAX: (718) 389-0098

Email: bk01@cb.nyc.gov

Website: www.nyc.gov/brooklyn1

HON. ERIC L. ADAMS
BROOKLYN BOROUGH PRESIDENT



SIMON WEISER
FIRST VICE-CHAIRMAN
DEL TEAGUE
SECOND VICE-CHAIRPERSON
STEPHEN J. WEIDBERG
THIRD VICE-CHAIRMAN
MARIA VIERA
FINANCIAL SECRETARY
SONIA IGLESIAS
RECORDING SECRETARY
PHILIP A. CAPONEGRO
MEMBER-AT-LARGE

DEALICE FULLER
CHAIRPERSON
GERALD A. ESPOSITO
DISTRICT MANAGER

HON. STEPHEN T. LEVIN
COUNCILMEMBER, 33rd CD
HON. ANTONIO REYNOSO
COUNCILMEMBER, 34th CD

June 11, 2019

CAPITAL BUDGET COMMITTEE REPORT

TO: Chairperson Dealice Fuller
and CB #1 Board Members

FROM: Stephen J. Weidberg, Committee Chair

RE: Budget Consultations and District Needs Statement for
Fiscal Year 2021

The Budget committee will meet to begin the process of updating agendas for the budget consultations and submitting a Statement of District Needs. The committee will review the proposed budget and evaluate the responses to our budget priorities.

Please check on line for the District Needs Statement. The Capital Budget Committee will be preparing a new statement for the next fiscal year (2021). The draft document will be presented to the full board for adoption in September. Your input is requested in making any changes.

Kindly submit your suggestions/comments in writing to the attention of the Capital Budget Committee. You can send your comments via email to bk01@cb.nyc.gov. You can also submit a hard copy your comments in writing via regular mail, or you can bring a hard copy with you to the board's office.

DEADLINE FOR WRITTEN COMMENTS IS MONDAY, JUNE 24, 2019.

The committee will meet on Wednesday, June 26, 2019 at 6:30PM in the CB #1's District Office, 435 Graham Avenue, Brooklyn, NY 11211 (Corner of Frost Street)



COMMUNITY BOARD NO. 1

435 GRAHAM AVENUE – BROOKLYN, NY 11211

PHONE: (718) 389-0009

FAX: (718) 389-0098

Email: bk01@cb.nyc.gov

Website: www.nyc.gov/brooklyn1

HON. ERIC L. ADAMS
BROOKLYN BOROUGH PRESIDENT



SIMON WEISER
FIRST VICE-CHAIRMAN
DEL TEAGUE
SECOND VICE-CHAIRPERSON
STEPHEN J. WEIDBERG
THIRD VICE-CHAIRMAN
MARIA VIERA
FINANCIAL SECRETARY
SONIA IGLESIAS
RECORDING SECRETARY
PHILIP A. CAPONEGRO
MEMBER-AT-LARGE

DEALICE FULLER
CHAIRPERSON
GERALD A. ESPOSITO
DISTRICT MANAGER

HON. STEPHEN T. LEVIN
COUNCILMEMBER, 33rd CD
HON. ANTONIO REYNOSO
COUNCILMEMBER, 34th CD

June 11, 2019

TRANSPORTATION COMMITTEE REPORT

TO: Chairperson Dealice Fuller and CB #1 Board Members
FROM: Mr. Eric Bruzaitis, Committee Chair
RE: Committee Report from Tuesday, May 21, 2019 Meeting

The Transportation Committee met Tuesday, May 21, 2019 (CALLED TO ORDER: 6:38 PM; ADJOURNED: 8:19 PM) in the SWINGING 60's SENIOR CITIZEN CENTER, BROOKLYN, NY 11211 (CORNER OF FROST STREET).

ATTENDANCE:

Present: Bruzaitis; Weiser; Elkins; Gallagher; Odomirok; Schlesinger.
Absent: Argento; Gangone; Green; Kuonen; Nieves (excused); Stuart; Solano. (A quorum was not met.)

COMMITTEE HELD PUBLIC HEARING

- 1. PRESENTATION: NYC DOT RE: THE PROPOSED CONNECTION OF THE OUTFLOW FROM THE BIKE WAY AND PEDESTRIAN WALKWAY (WESTBOUND) FROM THE KOSCIUSZKO BRIDGE (Phase II) – by Mr. Ted Wright, Director of Bicycle & Greenway Program, NYC DOT, Tel: (212) 839-7199, email: twright2@dot.nyc.gov and Mr. Craig Baerwald, Project Manager, NYC DOT, Tel: (212) 839-7227, email cbaerwald@dot.nyc.gov.**

As a follow up to the April 4, 2019 Public Hearing on this item, Mr. Ted Wright appeared to update the committee & public on the concerns raised at that time. Mr. Wright, who did not appear at the April meeting. Mr. Wright also stated that he could not be more specific about the connections to the bike network plans for Meeker Avenue at this time due to the expedited September opening of the North K Bridge. With respect to the issues raised below (as well as those brought up at the April Meeting). Mr. Wright has made a commitment to review the concerns listed below and return at a future Transportation Cmte meeting to review improvements to the existing plan. He also noted that since the plan is not fully complete to meet all the concerns of both the DOT

and the Board, more plans will be forthcoming, particularly as regards better connections to the existing bike network.

Committee members emphasized the following concerns:

- The biggest concern raised by both the committee and the public was the lack of signage and other traffic calming measures necessary to reduce motorist speeds exiting the BQE. There is significant evidence to suggest that motorists exiting at the Morgan Avenue exit DO NOT SLOW DOWN. They race to make the light at Apollo and are in a 'highway mentality' that does not trigger attention to slower traffic, pedestrians, cyclists and other cautions once off the BQE. Particular concern is still that cyclists will share the roadway before jogging right onto Van Dam Street. This is especially problematic since many of the large trucks have significant blind spots that are a danger to all road users at this location regardless of vehicle speeds. Officer Molina of the 94th Precinct was asked to provide accident data for this location: Since 2016 there have been 28 accidents (including on the bridge itself that may have been reported once the parties exited the BQE). Regardless of the nature of the causes, it is clear that this number of accidents should prompt the MOST ROBUST mitigation by both state and city Depts of Transportation.
- Inadequate signage for cyclist/pedestrians for way-finding off the bridge.
- Inadequate lighting both at the base of the exit ramp as well as at Apollo/Meeker BQE overpass.
- Because this plan does not include a fully conceived connection to the existing bike network, cyclists are likely to find the most direct routes both West and Southbound. The connections as presented are unreasonable in their expectations to expect cyclists to travel away from their desired route in order to connect at a more remote area of their trip. DOT must revise the network to accommodate a more intuitive plan for the growing number of cyclists expected to access the bridge both for commuting and for pleasure.
- Current sidewalk parking East of Apollo.
 - UPDATE: OFFICER MOLINA OF THE 94TH PCT HAS REPORTED THAT NCO'S HAVE BEEN MADE AWARE OF THIS ISSUE AND HAVE BEGUN A REGULAR PATTERN OF ENFORCEMENT TO TICKET THOSE VEHICLES ILLEGALLY PARKED ON THE SIDEWALK.
- Based on the "greenspace" improvements of the exit-island and Northside sidewalk of Meeker, trash collection may lead to a blockage on Meeker that will force cyclists on to the sidewalk creating a dangerous condition for them and pedestrians.
- (With the public) light timing at Apollo and countdown clocks needed re-evaluation before the full bridge reopens. The "walk/don't walk signal" has been knocked down twice in recent months.
- Additional signage will be necessary for the new park to avoid distracted cyclists & pedestrians looking for the best way to access the park once over the bridge.
- Despite the committee's understanding that the expedited timeline for the bridge's full opening, there was still disappointment that with the years available to DOT leading up to the bridge demolition and reopening, a more comprehensive plan should have been ready for presentation earlier, so that both the Board and the public would have the chance to raise concerns in time for DOT to fine tune this difficult traffic area.
- PUBLIC concerns mirrored those of the committee but also included concerns that existing striping of bike path is significantly worn out and needs immediate maintenance. The public was encouraged to log specific locations thru 311, the Board Office as well as the DOT website for follow-up. There was also concern that 'greenwashing' (a false sense of security that because there is a park and other green features equals calmer traffic conditions) will bring more traffic of all kinds to a location that is not adequately equipped to safely direct road users to the safest routes.

Members of the public recognized: Christine Holowacz; Jeff Csicsek; Philip Leff; Mary Gottlieb.

Please see testimony below by Max Sholl which was received by the Board Office, May 20, 2019:

Hi Eric, Transpo Cmte and the rest of the board!

I'm reaching out because I will be unable to make the meeting tomorrow evening, but I would like to submit comments to be included in your report as part of the public record, please. This is regarding two different presentations by NYC DOT.

1. Proposed Connection [of the Bike & Pedestrian Path] from the Kosciuszko Bridge

- The two blocks of Meeker Avenue between Apollo St & Driggs Ave should be a parking protected bike lane against the curb. The current plan maintains two vehicular travel lanes, which will create highway-like conditions, putting those who walk and bike here in danger on what should be a neighborhood street
- I also implore NYC DOT to expeditiously put a plan together to implement a greenway and other beautification elements under the BQE between Morgan Ave & Metropolitan Ave.

2. Grand Street Protected Bike Lane

- I implore NYC DOT to include pedestrian islands at all intersections on both sides of Grand St between the bike lane and vehicular travel lanes. Doing so will reduce crossing distance for pedestrians significantly, making Grand St a safer place to walk, shop and enjoy.

Thank you!
Max

Maximillian Sholl
718 309 5372
MaxSholl@gmail.com
@MaxSholl

2. DOT'S FINAL PLAN FOR THE GRAND STREET PROTECTED BIKE LANE – DOT will be making the bike lanes along the Grand Street corridor in Brooklyn permanent. Between Waterbury Street and Vandervoort Avenue, DOT will modify the protected bike lanes to help accommodate the needs of industrial businesses along this section of the corridor. The project will also include other adjustments made in response to community and business feedback including additional metered parking and new loading zones around the corners from Grand Street – by Brooklyn Borough Commissioner Keith Bray and Ms. Ronda J. Messer, Director, Community Affairs, Brooklyn DOT Office, Tel: (646) 892-1356, email: rmesser@dot.nyc.gov.

Mr. Ted Wright reviewed the full board presentation of May 14, 2019.

Committee members emphasized the following concerns:

- The decision to put bike lane at curb along the Waterbury-Morgan industrial corridor is almost certainly more dangerous condition than with the traffic.
- Loading zones as planned for Northside of Grand St on commercial corridor will not be adequate to serve the Southside businesses, will create an unsafe condition for deliveries, will increase the amount of bike-lane parking and double parking, despite the wider buffer planned, this will still create an unsafe condition.
- Loss of Alternate Side Parking on side streets in favor of metered parking will be a concern to residents who have an historic expectation of parking. It is also unclear that relocation of metered parking to these locations are an appropriate fix to support businesses along Grand St, particularly those on the Northside
- Concerns over business vacating, or turnover

Erin Priscopink: It is not possible at this time to determine how much the partial treatments contributed to businesses leaving although there is some anecdotal evidence. Businesses fail/relocate for many reasons, we will have to see once the new plan is implemented what this has contributed overall.

The committee will make this item a semi regular agenda item to assess the conditions post full installation. Because the resurfacing of Grand St was postponed in expectation of the L Train shut down, there will be a future date certain when this corridor will be resurfaced. The committee will expect a more formal public process to determine which features have been successful and which have cause more problematic conditions.

Our hope is that this very bad and hurried process will be more responsibly adjusted at that time.

Public recognized speakers: Erin Priscopink; Michael Shoder; Ariel Moskowitz; Brian Howel (BK02); Sal Buccio.

- There are recorded business losses along the commercial corridor since the partial implementation of Grand Street treatments. This plan was not a true public process as other street treatments have been done. Many of the concerns of all interested parties could have been better addressed and implemented had the regular process been used.
- A 2-way bike lane along the Northside industrial corridor, particularly because this is more residential, would be a better option.
- Shop owners should be issued some kind of special permit for use all along to corridor to mitigate business operation challenges because of the new treatments.
- Many businesses' vendors are regularly ticketed for making deliveries although there is no reasonable alternative for them to make the delivery.
- Still anger that new treatments were laid down with little to no notice in advance.

- The bakery and veterinarian locations are unique and must be granted some kind of special treatment that is appropriate to their businesses. This may be a new curb cut, paint/signage, eased enforcement or other measures.
- According to National Association of Traffic Engineers, 2 way bike lanes are not recommended.
- Rush hour, no parking alt side regulations are good for both business and cyclists. DOT will look at this for future plans.
- Businesses have the burden of safe operations where the shared use of the street are concerned.
- With congestion pricing coming on line, this plan may work fine as vehicle traffic is reduced to avoid tolls on Manhattan side.
- Loading zones must be put on both sides of Grand Street.
- This plan offers a false sense of security and there will be more accidents.

The next meeting of the Transportation Committee is scheduled for:

Monday, June 17, 2019 at 6:30 PM, in the CB#1's District Office, 435 Graham Avenue, Brooklyn, NY 11211 (Corner of Frost Street).

5/21 BK CB 1 Transportation Meeting

Max Sholl <maxsholl@gmail.com>

Mon 5/20/2019 2:51 PM

Inbox

To: BK01 (CB) <bk01@cb.nyc.gov>; eric bruzaitis <ebruzaitis@yahoo.com>;

Hi Eric, Transpo Cmte and the rest of the board!

I'm reaching out because I will be unable to make the meeting tomorrow evening, but I would like to submit comments to be included in your report as part of the public record, please. This is regarding two different presentations by NYC DOT.

1. Proposed Connection [of the Bike & Pedestrian Path] from the Kosciuszko Bridge

- The two blocks of Meeker Avenue between Apollo St & Driggs Ave should be a parking protected bike lane against the curb. The current plan maintains two vehicular travel lanes, which will create highway-like conditions, putting those who walk and bike here in danger on what should be a neighborhood street
- I also implore NYC DOT to expeditiously put a plan together to implement a greenway and other beautification elements under the BQE between Morgan Ave & Metropolitan Ave.

2. Grand Street Protected Bike Lane

- I implore NYC DOT to include pedestrian islands at all intersections on both sides of Grand St between the bike lane and vehicular travel lanes. Doing so will reduce crossing distance for pedestrians significantly, making Grand St a safer place to walk, shop and enjoy.

Thank you!

Max

--

Maximillian Sholl

718 309 5372

MaxSholl@gmail.com

@MaxSholl



COMMUNITY BOARD NO. 1

435 GRAHAM AVENUE - BROOKLYN, NY 11211

PHONE: (718) 389-0009

FAX: (718) 389-0098

Email: bk01@cb.nyc.gov

Website: www.nyc.gov/brooklyncb1

HON. ERIC L. ADAMS
BROOKLYN BOROUGH PRESIDENT



SIMON WEISER
FIRST VICE-CHAIRMAN

DEL TEAGUE
SECOND VICE-CHAIRPERSON

STEPHEN J. WEIDBERG
THIRD VICE-CHAIRMAN

MARIA VIERA
FINANCIAL SECRETARY

SONIA IGLESIAS
RECORDING SECRETARY

PHILIP A. CAPONEGRO
MEMBER-AT-LARGE

DEALICE FULLER
CHAIRPERSON

GERALD A. ESPOSITO
DISTRICT MANAGER

HON. STEPHEN T. LEVIN
COUNCILMEMBER, 33rd CD

HON. ANTONIO REYNOSO
COUNCILMEMBER, 34th CD

June 11, 2019

Commissioner William Heinzen
NYC Taxi & Limousine Commission
33 Beaver Street
New York, NY 10004

Dear Commissioner Heinzen:

Please be advised that at the regular meeting of Brooklyn Community Board No. 1, held on June 11, 2019, the members unanimously voted to support the renewal application for the following base license:

Brooklyn Radio Dispatcher Inc.
232 Metropolitan Avenue #1
Brooklyn, NY 11211

The vote was: 36 "YES"; 0 "NO"; 0 "ABSTENTIONS"; 0 "RECUSALS".

Working for a Safer Williamsburg-Greenpoint.

Sincerely,

Dealice Fuller
Chairperson

DF/mbw
Attachment: 1

Brooklyn Radio Dispatcher Inc.

232 Metropolitan Ave #1

Brooklyn, NY 11211

B01312

212-234-8000

Brooklyn 1 Community District

Chairperson: Dealice Fuller

**435 Graham Avenue
Brooklyn, NY 11211**

19 JUN 7 2:03 PM

Brooklyn Radio Dispatcher Inc. is a customer base radio dispatch in its renewal and relocation stages. It is being organized to provide radio dispatch service to their affiliated vehicles and drivers and collaborated with the transportation service in the community. The management of Brooklyn Radio Dispatcher Inc. is experienced in base radio dispatch start-ups. Previously, management grew several corporations in transportation business where they learned the experience about radio dispatch business.

The Company has the following objectives:

- To obtain required NYCTLC certifications on or before June 30, 2019.**
- To keep and maintain an elite company proud of doing business for the community.**
- TO OBTAIN A LETTER OF NO OBJECTION FROM YOUR OFFICE.**

19 JUN 7 2:03 PM

Company Locations and Facilities

Brooklyn Radio Dispatcher Inc. is located at 232 Metropolitan Ave #1, Brooklyn, NY 11211.

Brooklyn Radio Dispatcher Inc. has a mission to provide safe, efficient, low-cost consumer service. Our service will emphasize safety as its highest priority. We operate the newest and best maintained cars available. We will never skimp on maintenance in any fashion whatsoever. We will strive to operate our trips on time. We will provide friendly and courteous service. We will keep tracking our system as to keep unlicensed activities out.

- Obtaining the required governmental approvals.**
- Securing financing.**
- Experienced management. (Already in place).**
- Marketing; either dealing with channel problems and barriers to entry; or solving problems with major advertising and promotion budgets. Targeted market share must be achieved even amidst expected competition.**

• According to the Highway Capacity Manual published by the Transportation Research Board, the typical service volume for an urban street (refer to the table entitled “Example Service Volumes for Urban Streets” on page 10-10) for a two-lane roadway is 1200 vehicles per peak hour assuming an average level of service (LOS) C. The typical service volume for a one-lane roadway is 540 vehicles per peak hour using the same parameters and source.

• Any trip generation created by the proposed action on both streets per peak hour will not significantly impact the current use of either roadway and will not exceed the threshold of 50 peak hour vehicle trips outlined in CEQR 8 Technical Manual Section 3O-200. In addition, comparing the estimated new total of trips per peak hour (852) to the maximum capacity permitted on the two-lane roadway (1200) and (540) during a peak hour, the action will not result in significant traffic impacts on the project area as a whole.

Sincerely,

Quemi R. Familia

NYC TLC Industry Representative

quemifamilia@gmail.com 646-796-4864

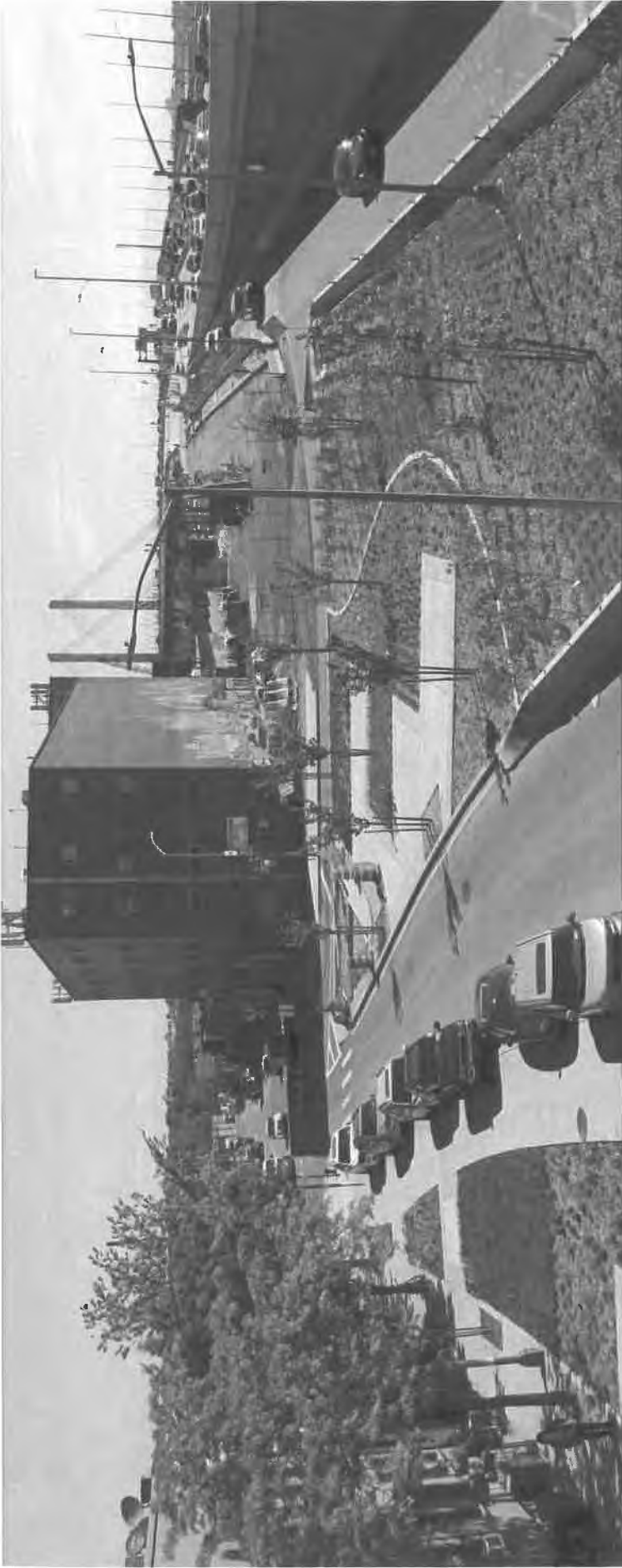

KOSCIUSZKO BRIDGE

Bike Connections Update

Presented to Brooklyn Community Board 1

May 21, 2019



Recap

1

Project Area

Kosciuszko Bridge (State DOT)

New Neighborhood Destinations

- Shared Use Path (Open 2019)
- Meeker Ave connection at bridge entrance, Van Dam St to Apollo St (Updated plan with SDOT)

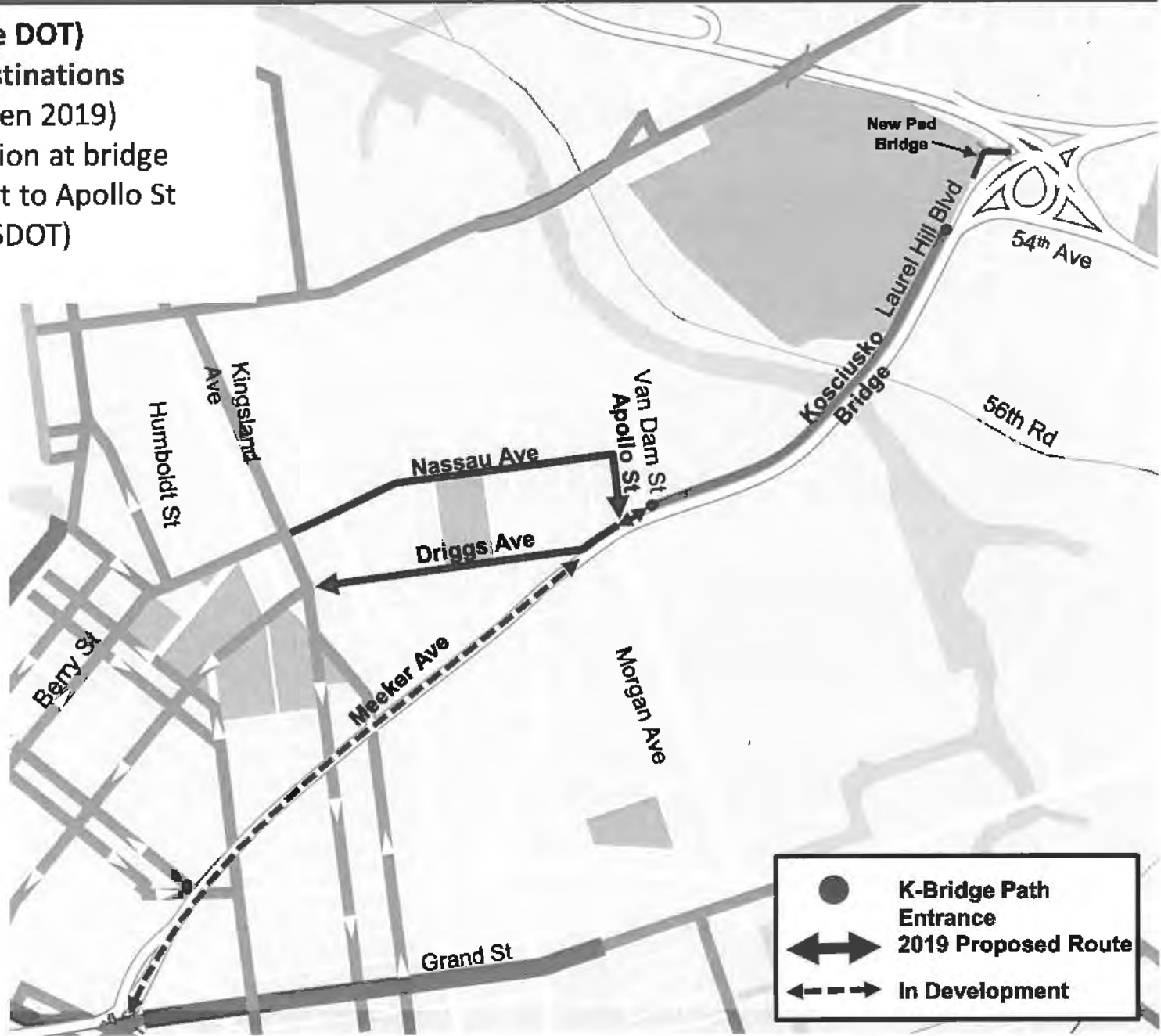

Kosciuszko Bridge Connection

Proposed

Bike Lanes

- Meeker Ave, Apollo St to Driggs Ave



Sub standard parking

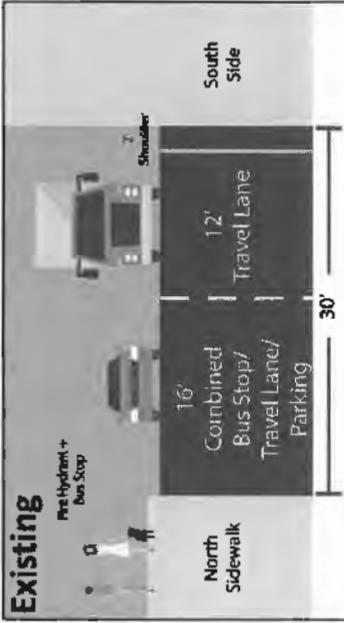

Updating regs would require the loss of 3 sub standard parking spaces

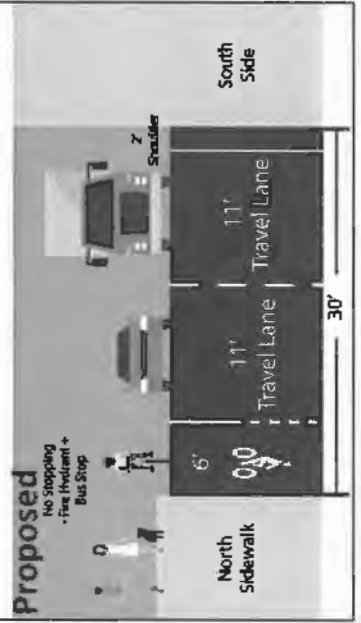

Apollo St to Hausman St

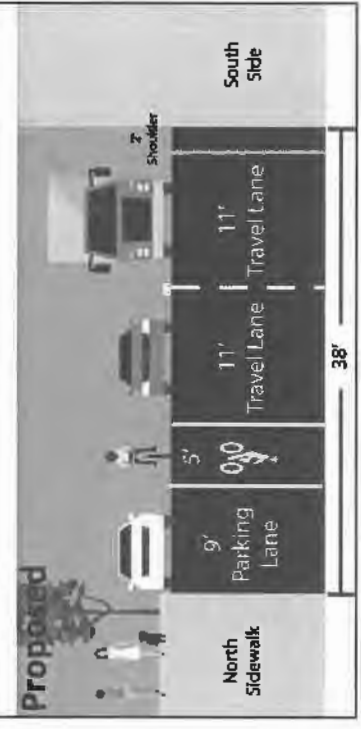
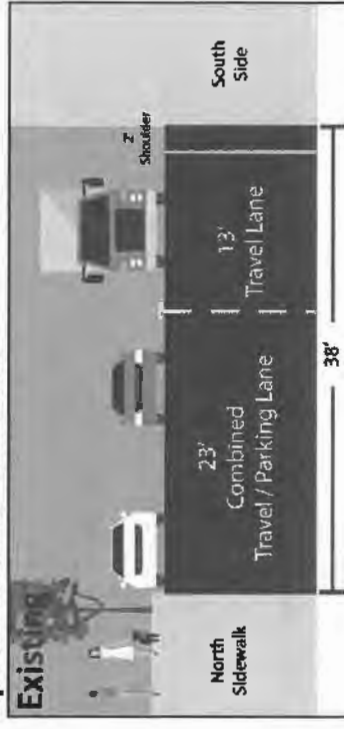

Kosciuszko Bridge Connection

Proposed



Driggs Ave, Meeker Ave to Leonard St
Apollo St, Nassau Ave to Meeker Ave



Nassau Ave, Leonard St and Apollo St

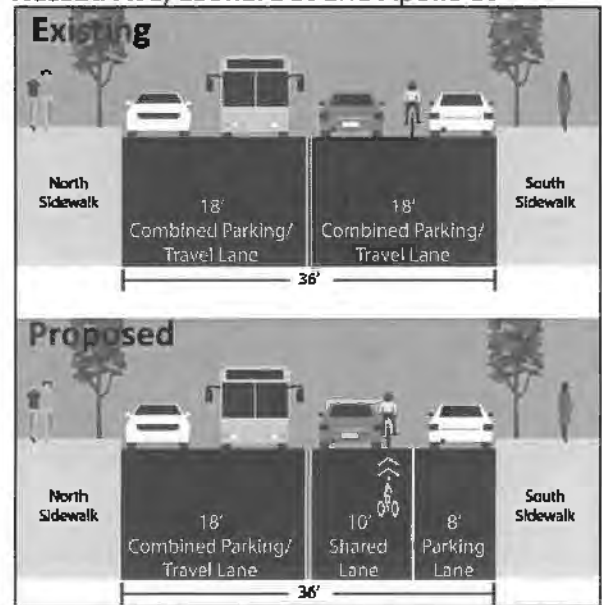
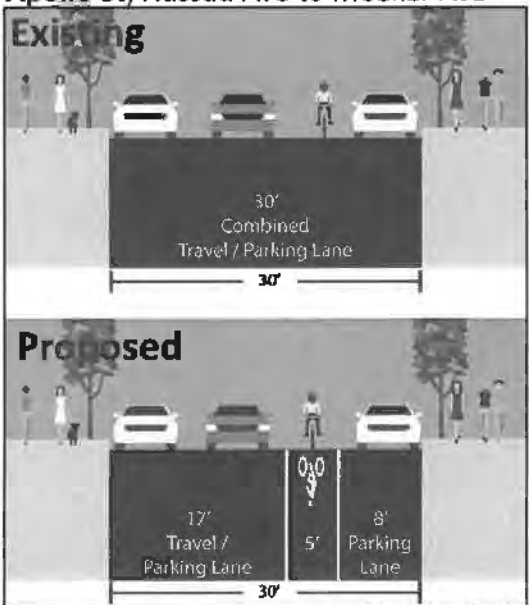

Update

2

Kosciuszko Bridge Connection

Proposed

Direct Pedestrian and Bike Connections to the Bridge

- New crosswalk and markings provide safe, direct connection to the Bridge Path Entrance
- SDOT and City DOT working together to provide new ramps, markings, and relocating signage

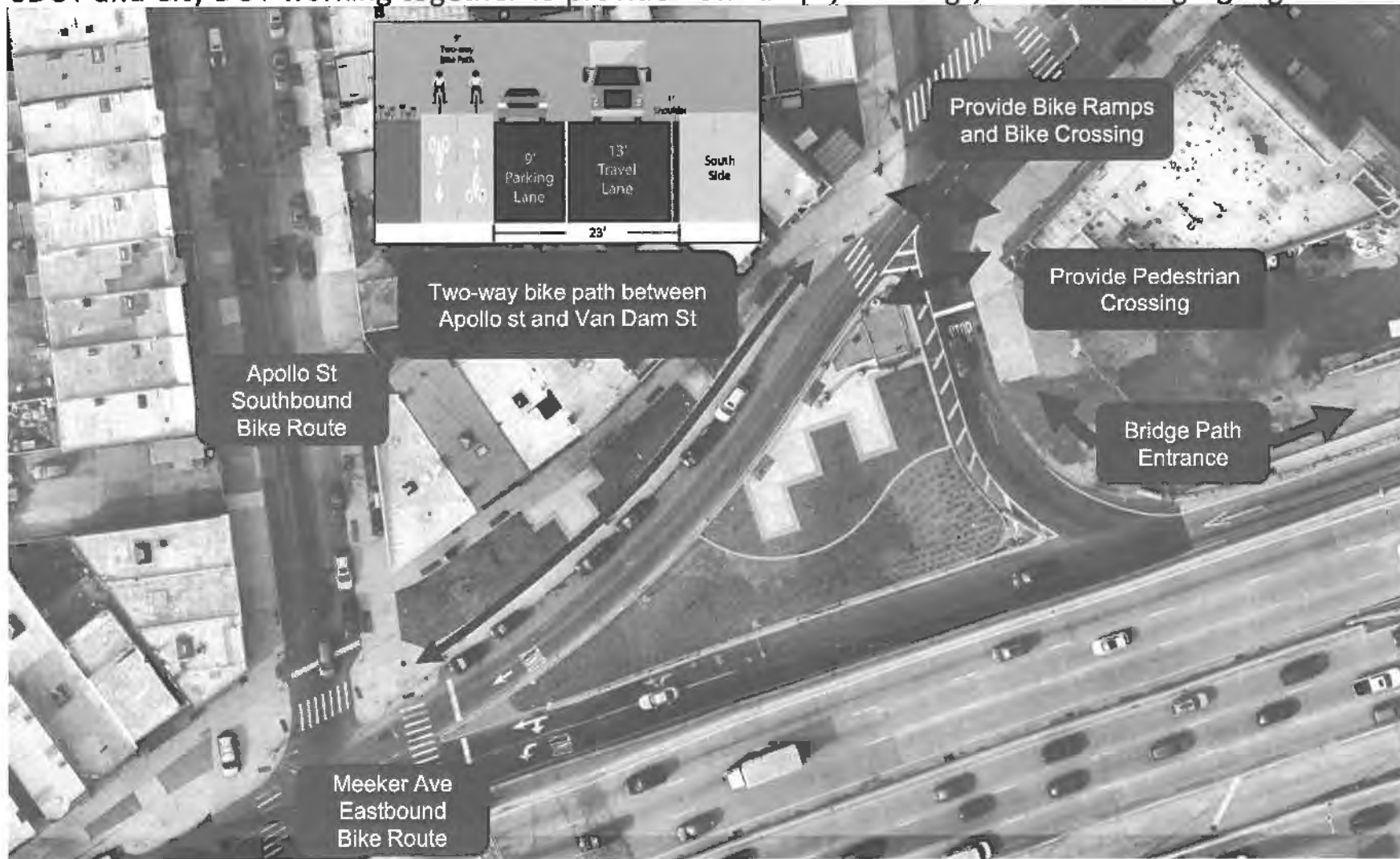

Kosciuszko Bridge Connection

Proposed

Direct Pedestrian and Bike Connections to the Bridge

- New crosswalk and markings provide safe, direct connection to the Bridge Path Entrance
- SDOT and City DOT working together to provide new ramps, markings, and relocating signage

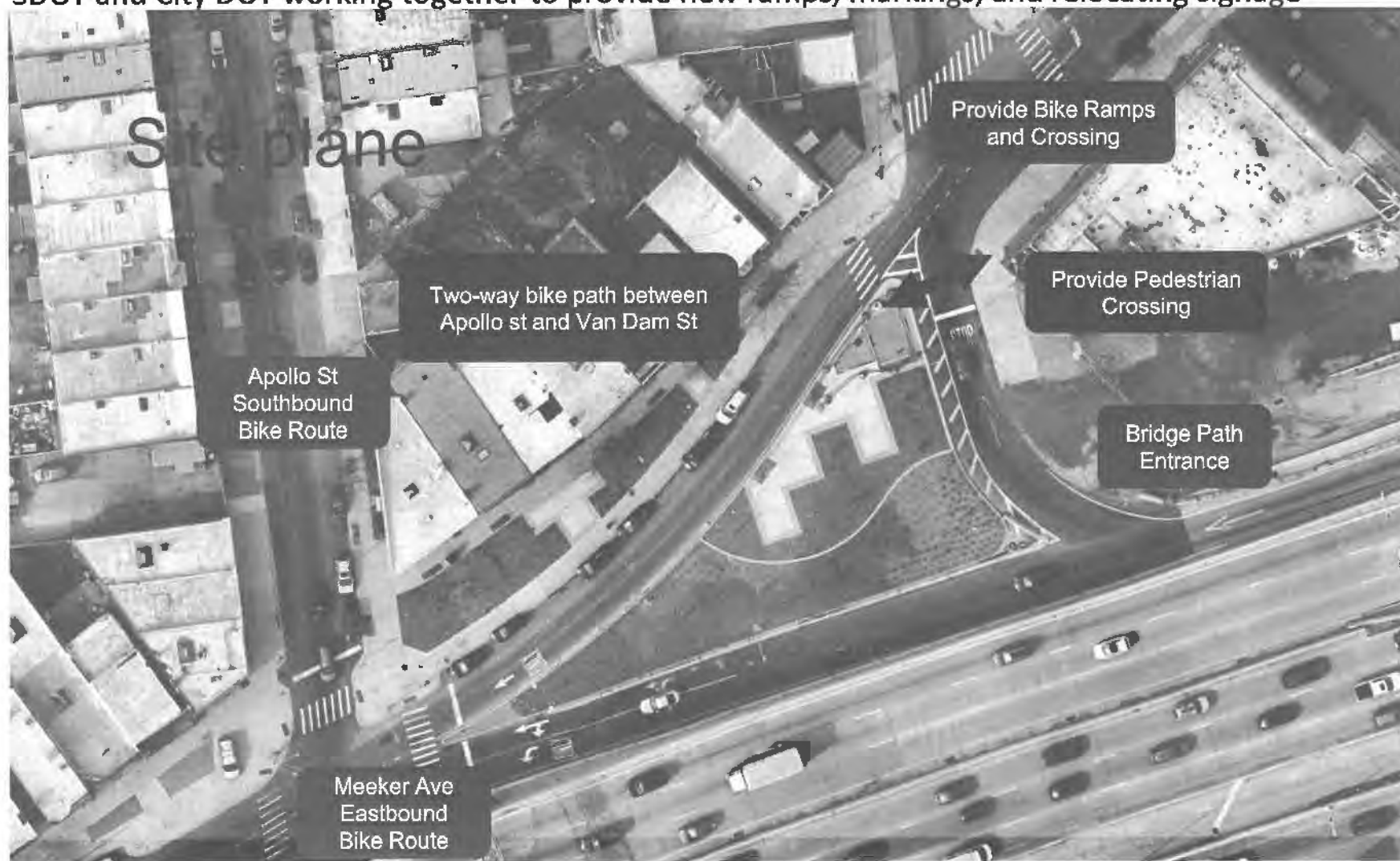

Kosciuszko Bridge Connection

Proposed

Direct Pedestrian and Bike Connections to the Bridge at Van Dam St



Two-way bike path between Apollo St and Van Dam St

Bridge Path Entrance

Provide Pedestrian Crossing

Provide Bike Ramps and Crossing

Summary

3

Summary of Benefits

Working with SDOT

- Direct pedestrian and bike connection to bridge path entrance from Meeker Ave

Improved Bike Network Connections

- Direct bike connections to and from the Kosciuszko Bridge Path
- Dedicated space for cyclists where feasible
- Maintains traffic capacity
- Updates parking regs
- Study future routes to the south

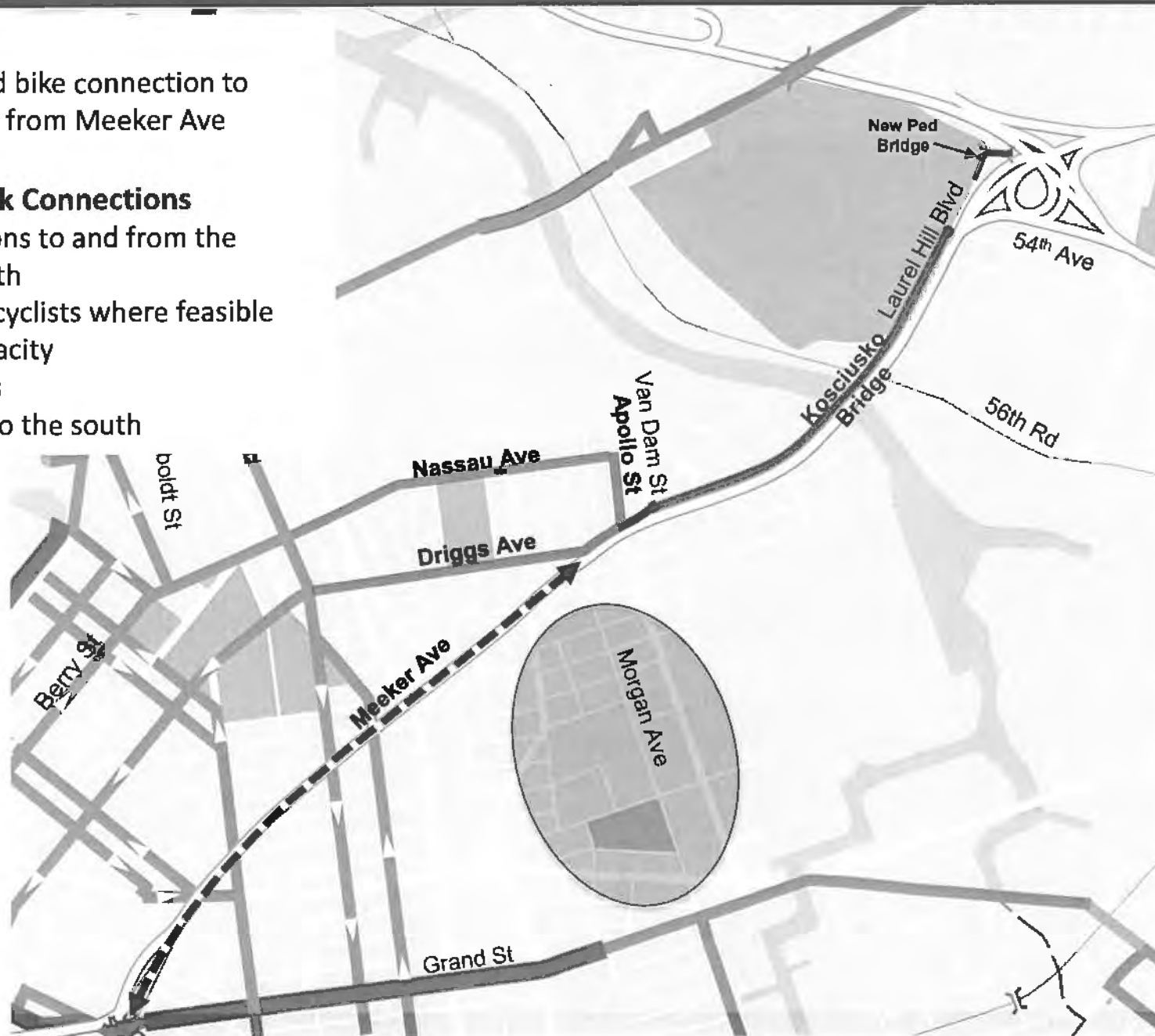

THANK YOU!

Questions?



NYCDOT



nyc_dot



nyc_dot



NYCDOT

Kosciuszko Bridge Connection

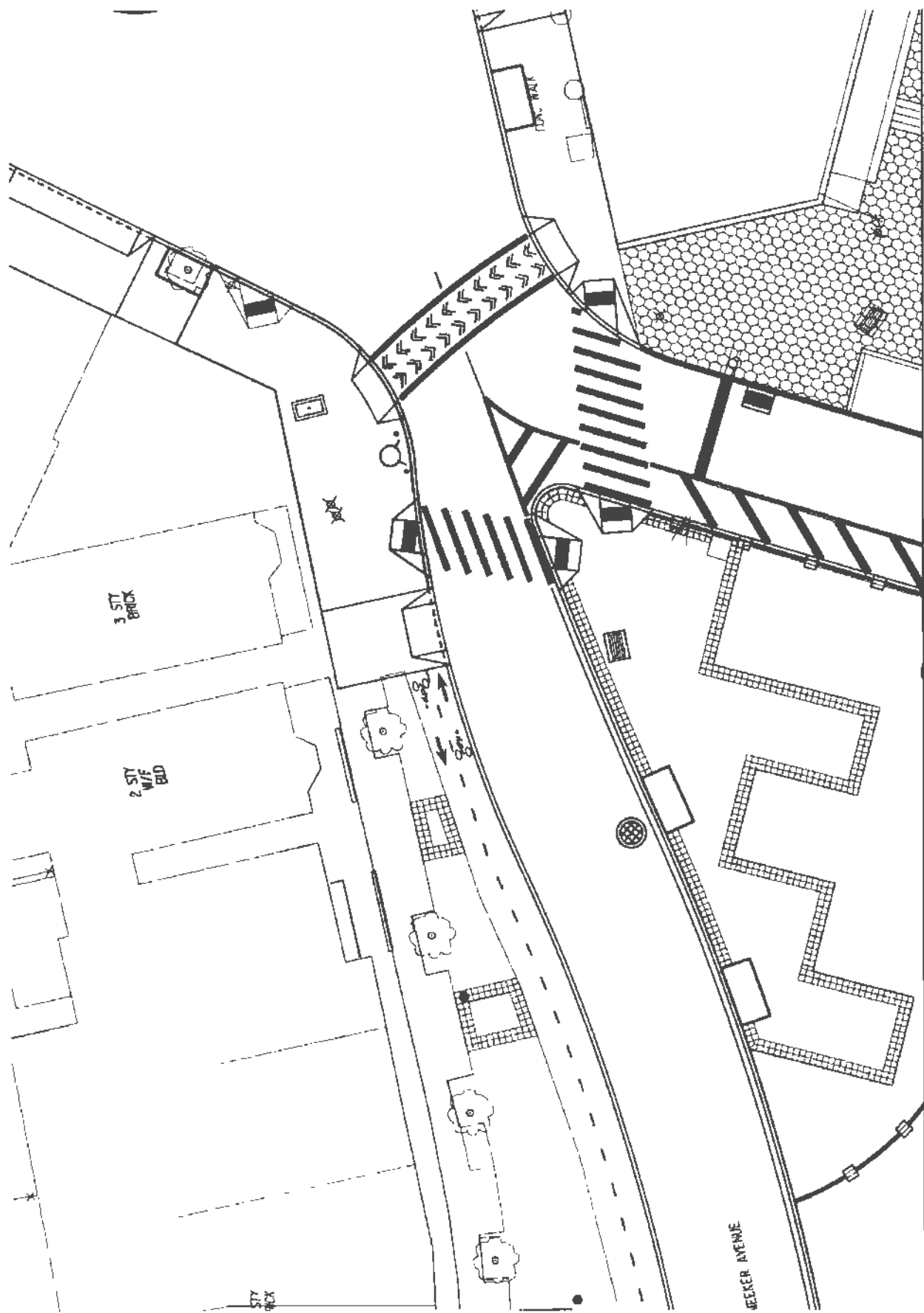

Kosciuszko Bridge Connection

Existing

Direct connection from Williamsburg Bridge to Kosciuszko Bridge with heavy volumes, complicated turns, and BQE ramps

Proposed (In Development)

Improved Connection to the Kosciuszko Bridge





COMMUNITY BOARD NO. 1
435 GRAHAM AVENUE – BROOKLYN, NY 11211

PHONE: (718) 389-0009

FAX: (718) 389-0098

Email: bk01@cb.nyc.gov

Website: www.nyc.gov/brooklyn1

HON. ERIC L. ADAMS
BROOKLYN BOROUGH PRESIDENT



SIMON WEISER
FIRST VICE-CHAIRMAN
DEL TEAGUE
SECOND VICE-CHAIRPERSON
STEPHEN J. WEIDBERG
THIRD VICE-CHAIRMAN
MARIA VIERA
FINANCIAL SECRETARY
SONIA IGLESIAS
RECORDING SECRETARY
PHILIP A. CAPONEGRO
MEMBER-AT-LARGE

DEALICE FULLER
CHAIRPERSON
GERALD A. ESPOSITO
DISTRICT MANAGER

HON. STEPHEN T. LEVIN
COUNCILMEMBER, 33rd CD
HON. ANTONIO REYNOSO
COUNCILMEMBER, 34th CD

June 11, 2019

Commissioner William Heinzen
NYC Taxi & Limousine Commission
33 Beaver Street
New York, NY 10004

Dear Commissioner Heinzen:

Please be advised that at the regular meeting of Brooklyn Community Board No. 1, held on June 11, 2019, the members unanimously voted to support the renewal application for the following base license:

Brooklyn Radio Dispatcher Inc.
232 Metropolitan Avenue #1
Brooklyn, NY 11211

The vote was: 36 "YES"; 0 "NO"; 0 "ABSTENTIONS"; 0 "RECUSALS".

Working for a Safer Williamsburg-Greenpoint.

Sincerely,

Dealice Fuller
Chairperson

DF/mbw
Attachment: 1

Brooklyn Radio Dispatcher Inc.

232 Metropolitan Ave #1

Brooklyn, NY 11211

B01312

212-234-8000

Brooklyn 1 Community District

Chairperson: Dealice Fuller

**435 Graham Avenue
Brooklyn, NY 11211**

19 JUN 7 2:03 P1

Brooklyn Radio Dispatcher Inc. is a customer base radio dispatch in its renewal and relocation stages. It is being organized to provide radio dispatch service to their affiliated vehicles and drivers and collaborated with the transportation service in the community. The management of Brooklyn Radio Dispatcher Inc. is experienced in base radio dispatch start-ups. Previously, management grew several corporations in transportation business where they learned the experience about radio dispatch business.

The Company has the following objectives:

- To obtain required NYCTLC certifications on or before June 30, 2019.**
- To keep and maintain an elite company proud of doing business for the community.**
- TO OBTAIN A LETTER OF NO OBJECTION FROM YOUR OFFICE.**

Ad 58:2 2 NOV 61

Company Locations and Facilities

Brooklyn Radio Dispatcher Inc. is located at 232 Metropolitan Ave #1, Brooklyn, NY 11211.

Brooklyn Radio Dispatcher Inc. has a mission to provide safe, efficient, low-cost consumer service. Our service will emphasize safety as its highest priority. We operate the newest and best maintained cars available. We will never skimp on maintenance in any fashion whatsoever. We will strive to operate our trips on time. We will provide friendly and courteous service. We will keep tracking our system as to keep unlicensed activities out.

- Obtaining the required governmental approvals.**
- Securing financing.**
- Experienced management. (Already in place).**
- Marketing; either dealing with channel problems and barriers to entry; or solving problems with major advertising and promotion budgets. Targeted market share must be achieved even amidst expected competition.**

• According to the Highway Capacity Manual published by the Transportation Research Board, the typical service volume for an urban street (refer to the table entitled “Example Service Volumes for Urban Streets” on page 10-10) for a two-lane roadway is 1200 vehicles per peak hour assuming an average level of service (LOS) C. The typical service volume for a one-lane roadway is 540 vehicles per peak hour using the same parameters and source.

• Any trip generation created by the proposed action on both streets per peak hour will not significantly impact the current use of either roadway and will not exceed the threshold of 50 peak hour vehicle trips outlined in CEQR 8 Technical Manual Section 3O-200. In addition, comparing the estimated new total of trips per peak hour (852) to the maximum capacity permitted on the two-lane roadway (1200) and (540) during a peak hour, the action will not result in significant traffic impacts on the project area as a whole.

Sincerely,

Quemi R. Familia

NYC TLC Industry Representative

quemifamilia@gmail.com 646-796-4864



COMMUNITY BOARD NO. 1

435 GRAHAM AVENUE – BROOKLYN, NY 11211

PHONE: (718) 389-0009

FAX: (718) 389-0098

Email: bk01@cb.nyc.gov

Website: www.nyc.gov/brooklyn1

HON. ERIC L. ADAMS
BROOKLYN BOROUGH PRESIDENT



SIMON WEISER
FIRST VICE-CHAIRMAN
DEL TEAGUE
SECOND VICE-CHAIRPERSON
STEPHEN J. WEIDBERG
THIRD VICE-CHAIRMAN
MARIA VIERA
FINANCIAL SECRETARY
SONIA IGLESIAS
RECORDING SECRETARY
PHILIP A. CAPONEGRO
MEMBER-AT-LARGE

DEALICE FULLER
CHAIRPERSON
GERALD A. ESPOSITO
DISTRICT MANAGER

HON. STEPHEN T. LEVIN
COUNCILMEMBER, 33rd CD
HON. ANTONIO REYNOSO
COUNCILMEMBER, 34th CD

June 11, 2019

COMMITTEE REPORT

TO: Chairperson Dealice Fuller
and CB#1 Board Members

FROM: Phil Caponegro, Committee Chair
Parks and Waterfront Committee

RE: Committee Report for May 29, 2019 Meeting

The Parks & Waterfront Committee held a meeting on Wednesday, May 29, 2019, at 6:00 PM, in at the Polish & Slavic Center, 176 Java Street, Brooklyn, NY 11222.

ATTENDANCE: Present – Caponegro; McKeever; Chesler; Elkins. Absent – Cianciotta; Cohen; Dybanowski; Odomirok; Peterson. (A quorum was not achieved.)

The Committee received a final presentation of the Design for the Box Street Park by the Parks Department. Summary of Meeting – Final Presentation of the Design for Box Street Park:

Mary Salig and Landscape Architect Sylvia Barnett of Stantec presented a revised design for Box Street Park, a new 2.5 acre waterfront park promised in the 2005 rezoning, located in Greenpoint at Box and Commercial Streets at the mouth of the Newtown Creek (sandwiched between the Greenpoint Landing and yet to be built 77 Commercial developments). The park will be constructed around a .3 acre site that will continue to house an MTA Emergency Response Unit until it can be relocated and the land incorporated into the park.

Box Street Park has a \$21.7m budget. A community scoping meeting took place in April 2018 and a preliminary design for the park was presented to the CB 1 Parks and Waterfront committee in November 2018. This initial design was summarily rejected by the committee due to a unanimous community call for a softer shoreline and direct access to the water (as outlined in the Waterfront Access Plan).

The committee and community response to the revised design was overwhelmingly positive. The design renderings show a soft riprap shoreline and a stone stepped "get down" to the water.

Additional design elements include:

- Planted upland overlook
- Large central lawn tilted to the Manhattan view
- Dog runs for large and small dogs (designed with drainage)
- A comfort station at the entrance to the park
- Basketball court
- Picnic area
- More trees and colorful seasonally blooming native plantings

Willis Elkins asked how legacy contamination of the site is being addressed. Parks and EDC said that a few soil hot spots will be remediated and in most of the park that contains non-hazardous affected soil will have the top layer excavated and covered with new soil. The committee requested details on the environmental analysis and planned remediation, specifically, the riprap shoreline.

Much of the discussion concerned expanding/widening the shoreline get down and as well as adding additional seating along the water edge. It was agreed that this area will be where park users congregate, the proposed amount of seating was found to be inadequate.

The Committee members present voted 4-0 to accept the design with the following recommendations:

- 1.) All environmental information is presented to the Community Board.
- 2.) Enlarge the width of the stepdown.
- 3.) Metal grates along the walkway over the water.
- 4.) Add more seating along the waterfront.
- 5.) Adding wood benches.

PC/mbw

cc: Board Members



NYC Parks

City of New York
Parks & Recreation
nyc.gov/parks

Community Board 1 Monthly Parks Update – June 11, 2019

Jaime Campiz Basketball Tournament

Sponsored by CM Antonio Reynoso, with the support of NYC Parks and the North Brooklyn Parks Alliance, the June 22nd event will feature basketball teams of varying levels. Please join us for the tournament and as we rename the basketball courts at Jaime Campiz.

McCarren Soccer Field Reminder

The goal posts for the McCarren Park soccer and football field will be installed in mid-August. Permit holders have been informed and the Brooklyn permit office is in the process of reconfiguring the permits on the field to accommodate as many permit holders as possible.

The McCarren soccer and football field will be closed for about a month from roughly mid-August to mid-September for this installation.

Rodney Park Renovations

The basketball court renovations at Rodney Park will be completed July 31, 2019. This refurbishment will completely resurface the courts, apply color seal coat, and replace old basketball hoops for new.

Summer Movies in Community Board 1

- June 14th Cooper Park
- June 15th at William Sheridan showing *The Goonies*
- June 21st at Transmitter Park (French Film Series)
- June 22nd at McCarren Park or McGolrick Park **Love, Simon**
- June 28th Transmitter Park
- July 12th at Transmitter Park
- July 19th at Transmitter Park
- July 25th at 50 Kent **Mamma Mia**
- July 26th at Transmitter Park
- July 30th at 50 Kent **A Star is Born**
- August 2nd, August 9th, and August 16th at Transmitter Park

Partnerships for Parks Updates

Please contact Delancey Nelson if you have any questions or to schedule a volunteer event in your local park:

Delancey.Nelson@parks.nyc.gov or 718.965.7710

| | | |
|---|-----------------------|--|
| June 25 th from 6:30pm - 8:30 pm | Brooklyn Borough Hall | Join us for our annual Brooklyn Parks Connections to meet other community members and get the latest expert advice on caring for parks in your borough. At this workshop, discover how |
|---|-----------------------|--|



| | | |
|---|---------------------|--|
| | | volunteers, city agencies, and elected officials collaborate to create thriving parks. |
| https://cityparksfoundation.org/events/brooklyn-parks-connections-2/?date=20190625 | | |
| June 22 nd from 2-4PM | Martinez Playground | TBD |

McCarren Recreation Center

- The McCarren Recreation Center will host a roller-skating party on June 14, 2019, from 3pm until 6pm. This event is free, open to all, but participants under 18 years of age must have parental supervision. All are encouraged to attend and bring their own skates!
- After the June 14th roller-skating event McCarren Recreation Center will screen the film "Woman on Fire", a documentary about the first NYC transgendered woman firefighter.
- On June 15, 2019 McCarren will be hosting a Book Fair.
- **McCarren Pool opening will be on 6/27/19**

Metropolitan Pool

- Please see the attached swim schedules.

CB1 currently has the following projects under construction:

- Jaime Campiz – construction began on courts spring 2018 and was completed summer 2018, adult fitness to be completed summer 2019;
- Newtown Barge Playground –upland park contractor began work February 2018, completion anticipated spring 2019;
- Ten Eyck Playground Comfort Station – to be complete spring 2019.

We have several projects not yet under construction:

- Ten Eyck Plaza – in design;
- William Sheridan Playground – in design;
- Bushwick Inlet Park – Motiva and 50 Kent – in design;
- Box Street Park – in design. Community Board 1 vote June 11, 2019;
- McCarren Recreation Center – reconstruction of roof and exterior masonry walls. Construction will begin spring 2019 and be completed in two years;
- Penn Triangle – construction to begin fall 2019;
- Sternberg Synthetic turf and basketball lights – construction likely to begin fall 2019 and be complete fall 2020;
- McCarren Park natural turf softball fields –construction anticipated to begin fall 2020;
- Bartlett Playground – construction to begin fall 2020;
- McGolrick Park Paths – to begin spring 2020 and completed spring 2021;
- Cooper Park Comfort station –construction to begin spring 2020;



- LaGuardia Playground – completing design phase. Sports courts construction to begin fall 2019 and be complete fall 2020. Playground Construction anticipated to begin spring 2020 and will be complete spring 2021;
- Epiphany Playground – construction start date unknown due to ongoing litigation.

Funded projects awaiting a public input meeting:

- Marcy Parks.

GreenThumb Updates

- Members of the public who are interested in getting involved at any GreenThumb gardens in Brooklyn Community Board 1 can contact kc.alvey@parks.nyc.gov or 212-602-5326.
- **Lentol Garden:** The first phase of the renovation of Lentol Garden is nearing completion, thanks to the efforts of GrowNYC and funding from the Greenpoint Community Environmental Fund. Through a number of volunteer workdays, GrowNYC has installed new pathways, seating, a shed, and a composting system (with concrete pads underneath to prevent rats). Over the past several months, GrowNYC and volunteers have worked to clear and remove weeds and lay mulch throughout the garden. NYC Parks delivered mulch for a workday at the garden on Wednesday 6/6. Garden members have also planted new native plants and ornamentals throughout the garden. The volunteer-run garden group has received many interested new members this spring and they are in the process of drafting their bylaws per GreenThumb requirements. They held a meeting on Tuesday 6/4 and will hold another garden meeting in the next few weeks. A pollinator garden will also be designed and installed by the Wallerstein Collaborative for Urban Environmental Education at NYU in consultation with garden members during the 2019 growing season, as part of an environmental education grant from the U.S. Environmental Protection Agency. The garden has also received regular rat abatement from Parks Exterminator.
- **Red Shed Garden:** Garden members have planned a full calendar of events and workdays for the 2019 season at Red Shed Garden, including a Summer Party open to the public on Saturday 6/22. More information is available at <http://www.redshedgarden.com/calendar>.
- **I.S. 318 Project Roots:** This garden has received a number of physical site improvements over the past several months, thanks to support from the GreenThumb Operations team. Debris and deteriorating raised beds were removed, the site was levelled and graded, and new raised beds were constructed. After a series of visioning workshops for students and community members held by GreenThumb this spring, we have been working to redesign and rebuild the garden. Students and volunteers helped fill the new raised beds with clean soil and spread woodchips throughout the paths. A volunteer workday was held on Saturday 5/11 with GreenThumb to fill raised beds and prepare the garden for planting. This garden is actively looking for new members to care for the garden year-round and to continue filling new raised beds that are open to the community. Contact kc.alvey@parks.nyc.gov or 212-602-5326 to learn more about getting involved at I.S. 318 Project Roots.



NYC Parks

- **Berry Street Garden:** The GreenThumb Operations team has worked to remove debris and a casita that had fallen into disrepair at Berry Street Garden. The garden also received new internal fencing this spring from GreenThumb. Garden members are in the process of drafting and updating their bylaws, with several recent garden meetings on Saturday 5/18, Sunday 6/2, and Thursday 6/6. The volunteer-run garden group is also exploring fundraising options to design and construct a new casita for the garden.
- **Powers Street Garden:** A GreenThumb workshop was held at this garden in collaboration with Powers Street Garden on Tuesday 6/4 called "Raised Bed Design: Wheelchair Accessible Table-Top Raised Beds." GreenThumb staff led this workshop to demonstrate how to build a table-top raised bed and to share ways to make gardens accessible to everyone, regardless of age or mobility. Powers Street Garden members also recently held a workday and garden meeting on Saturday 5/11 to clean the garden and review the garden's bylaws.
- **Oko Farms:** A GreenThumb workshop was held at this site on Wednesday 5/22 called "Sharing our Farm Traditions: Oko Farms" on aquaponics systems. Oko Farms is a GreenThumb community garden known for its aquaponics system — a hybrid of aquaculture and hydroponics that raises freshwater fish along with a variety of vegetables and fruits.

Other GreenThumb Initiatives:

- **North Brooklyn Gardeners:** On Tuesday, May 5/21, community garden leaders from throughout North Brooklyn participated in the second meeting this spring with NYC Parks GreenThumb at Los Sures Senior Housing, as a follow-up from an initial meeting in March. We focused the discussion on planning community events at different gardens throughout the area, as part of the second annual Open Garden Day citywide on July 20th with GreenThumb. We also talked about joint outreach strategies to maximize attendees and to promote the value of community gardens. A June meeting will be held on Tuesday 6/18. For more information, contact kc.alvey@parks.nyc.gov or 212-602-5326.
- **Relicensing with NYC Parks:** GreenThumb gardens on NYC Parks property are in the process of renewing their license agreements with NYC Parks for the 2019-2022 period. A series of information sessions are being held throughout the city during June and July for designated garden contacts to learn about updates to the license agreement and to submit required paperwork.
- **2019 GreenThumb Gardeners' Handbook:** The 2019 edition of the GreenThumb Gardeners' Handbook is now available. This handbook answers frequently asked questions regarding a variety of topics, including accepting donations, selling garden produce, tree pruning, and garden bylaws. It is a one-stop-shop for all GreenThumb, NYC Parks, NYC, and NY State policies and laws that govern community gardens in the GreenThumb network. To request print copies, contact kc.alvey@parks.nyc.gov or 212-602-5326.
- **Summer Program Guide:** The Summer Program Guide has a compilation of upcoming workshops and events that are free and open to the public from June through July. To request print copies, contact kc.alvey@parks.nyc.gov or 212-602-5326.



Upcoming Events:

- **Saturday 6/22 from 1-3PM: Rainwater Harvesting & Rain Gardening workshop at El Puente: Espiritu Tierra Community Garden:** *Facilitated by GrowNYC, Brooklyn Botanic Garden, and GreenThumb.* Join us for a discussion on the benefits of rainwater harvesting, and look at ways to design and maintain sustainable, effective rainwater harvesting systems and rain gardens. Please **RSVP on Eventbrite**. RSVP by Friday, June 14 to be eligible to receive plants for your community garden's rain garden, while supplies last. This workshop will be offered with Spanish and Bengali translation.
- **Monday 6/24 from 5:30-7PM: Meet-and-Greet at I.S. 318 Project Roots:** Come see what's growing at I.S. 318 Project Roots! We are looking for new members who are interested in caring for this newly-renovated school and community garden throughout the summer. Join NYC Parks GreenThumb for a meet-and-greet at the garden to learn about ways to get involved here. Share your ideas and meet other members of the public who are interested in stewarding this garden. Snacks will be provided. Please RSVP to kc.alvey@parks.nyc.gov or 212-602-5326.
- **Saturday 7/20 from 11AM-3PM: 2nd Annual Open Garden Day with NYC Parks GreenThumb** (citywide): GreenThumb will be hosting Open Garden Day NYC! Community Gardens across the city will open their gates to the public from 11 a.m. – 3 p.m. on Saturday, July 20, 2019 (rain or shine). More info and a listing of events will be available at <https://greenthumb.nycgovparks.org/>.

Metropolitan Pool & Fitness Center

261 Bedford Ave, Brooklyn, NY 11211

Telephone: (718) 599-5707 Fax: (718) 599-5745

NO DIVING

POOL SCHEDULE

NO JUMPING

June 16th – September 30th 2019

| SUNDAY | MONDAY | TUESDAY | WEDNESDAY | THURSDAY | FRIDAY | SATURDAY |
|--|-----------------------------------|-------------------------------------|-----------------------------------|------------------------------------|---|-----------------------------------|
| 10:00am - 12:30pm Adult Lap Swim | 7:00am - 9:55am Adult Lap Swim | 7:00am - 10:55am Adult Lap Swim | 7:00am - 9:00am Adult Lap Swim | 7:00am - 10:55am Adult Lap Swim | 7:00am - 9:55am Adult Lap Swim | 7:00am - 8:55am Adult Lap Swim |
| 12:30pm - 1:15pm Aqua Boot Camp | 10:00am - 11:00am Women's Swim | 11:00am - 1:00pm General Swim | 9:00am - 11:00am Women's Swim | 11:00am - 1:00pm General Swim | 10:0am - 10:45am Water Exercise | 9:00am - 2:00pm General Swim |
| 1:15pm - 2:45pm General Swim | 11:00am - 1:00pm General Swim | 1:00pm - 2:00pm Pool Cleaning | 11:05am - 1:00pm General Swim | 1:05pm - 4:05pm Adult Lap Swim | 11:00am - 1:00pm General Swim | 2:05pm - 3:35pm Water Polo |
| 2:45pm - 4:45pm Women & Girls Swim | 1:05pm - 3:55pm Adult Lap Swim | 2:00 pm - 3:55 pm Adult Lap Swim | 1:00pm - 3:55pm Adult Lap Swim | 4:15pm - 6:00pm General Swim | 1:00pm - 2:30pm Pool Maintenance | 4:00pm - 5:15pm Adult Lap Swim |
| | 4:00pm - 6:30pm General Swim | 4:00pm - 6:00pm General Swim | 4:00pm - 6:30pm General Swim | 6:00pm - 7:00pm Aqua Boot Camp | 2:30pm - 3:30pm Adaptive Swim Lessons | |
| | 6:35pm - 9:15pm Adult Lap Swim | 6:05 pm - 9:15 pm Adult Lap Swim | 6:35pm - 9:15pm Adult Lap Swim | 7:00pm - 9:15pm Adult Lap Swim | 3:30pm - 6:00pm General Swim | |
| | | | | | 6:00pm - 7:00pm Aqua Zumba | |
| | | | | | 7:00pm - 9:15pm Adult Lap Swim | |

**SWIM CAPS, WATER SHOES, AND FLIP FLOPS ARE RECOMMENDED,
NO STREET SHOES ARE PERMITTED ON THE POOL DECK
INDIVIDUALS MAY NOT USE ANY FLOATATION DEVICES IN THE POOL
INFANTS & TODDLERS MUST WEAR SWIM DIAPERS.**

**45 MAXIMUM POOL CAPACITY WHEN ONE (1) LIFEGUARD IS ON DUTY
POOL DIMENSIONS: 30 FEET WIDE BY 75 FEET LONG**

**NO BOOKBAGS, BACKPACKS, BAGS, OR ELECTRONICS/CELL PHONES
OF ANY KIND ARE ALLOWED ON POOL DECK
PLEASE SEE RECREATION STAFF FOR ADDITIONAL INFORMATION & RULES**



NYC Parks



“DON'T FORGET A LOCK”



MEMBER USE OF THE SWIMMING POOL

1. A SWIMMING CAP IS HIGHLY RECOMMENDED OF ALL MEMBERS.
2. EVERYONE MUST BRING THEIR OWN LOCK. NO SHARING LOCKS.
3. SWIMMERS MUST WEAR PROPER SWIM ATTIRE. ALL SWIM TRUNKS MUST HAVE LINING – NO BASKETBALL SHORTS. NO FLOATATION DEVICES/LIFEVESTS ARE PERMITTED.
4. IF A SHIRT IS WORN IN THE POOL IT MUST BE ONLY A WHITE SHIRT. NO COLORED SHIRTS WILL BE PERMITTED.
5. ALL SWIMMERS MUST SHOWER BEFORE ENTERING THE POOL DECK AREA.
6. NO ONE IS ALLOWED ON POOL DECK IN STREET CLOTHES OR SHOES, SNEAKERS OR BOOTS.
7. ALL ITEMS MUST BE REMOVED FROM THE LOCKERS DAILY, LOCKS ARE CLIPPED EVERY EVENING AND ITEMS REMOVED.

FITNESS & CARDIO ROOM

MONDAY – FRIDAY – 7:00 am – 9:30 pm

MONDAY – FRIDAY – 7:00 am – 9:30 pm

MONDAY – FRIDAY – 7:00 pm – 9:30 pm

MONDAY – FRIDAY – 7:00 pm – 9:30 pm

SATURDAY – 7:00 am – 5:30 pm

SUNDAY – 10:00 am – 5:30 pm

*****FITNESS ROOM IS CLOSED DAILY FROM 2:30 pm – 3:00 pm FOR CLEANING*****

1. PROPER WORK OUT CLOTHES MUST BE WORN (NO JEANS, BOOTS, DRESS SHOES, ETC.)
 2. ALL MEMBERS MUST HAVE THEIR OWN TOWEL (NO WASH CLOTH OR TORN SHIRT)
 - A) NO BAGS, OUTER CLOTHING OR OTHER ITEMS ARE ALLOWED INSIDE PROGRAM AREAS.
 - B) MEMBERS ARE TO LOCK ALL ITEMS IN LOCKER. (SMALL PERSONAL ITEMS CAN BE LOCKED IN SMALL LOCK BOXES IN THE MAIN LOBBY.
 - C) NO ITEMS ARE TO BE LEFT IN LOCKERS OVERNIGHT. (LOCKS ARE CLIPPED EVERY EVENING)
- IF THERE ARE MEMBERS WAITING TO USE A MACHINE AND NONE IS AVAILABLE, A TWENTY (20) MINUTE LIMIT WILL BE ADHERED TO. PLEASE BE AWARE SOME MACHINES ARE RESERVED FOR PROGRAM SPECIFIC USE AT CERTAIN TIMES.

LOCKER ROOM RULES

1. NO EATING IS PERMITTED IN THE LOCKER ROOMS.
2. ALL ITEMS MUST BE REMOVED FROM THE LOCKERS DAILY, LOCKS ARE CLIPPED EVERY EVENING AND ITEMS REMOVED.

Metropolitan Pool & Fitness Center

Metropolitan Pool, & Fitness Center in the Williamsburg section of Brooklyn, was built under the auspices of Borough President Edward Riegelmann in 1922. The pool and bath were designed by the noted Lincoln Memorial architect Henry Bacon (1866-1924). It was the eighth of nine municipal bath houses erected by the Department of Public Works, in order to promote public health, hygiene and recreation.

In 1922 annual use of the city's bathhouses was a remarkable 13 million visits. Overseeing Brooklyn municipal construction were Joseph A. Guider, Commissioner of Public Works and James J. Byrne, Superintendent of Public Buildings, each of whom later served as Borough President.

In 1935 the structure was turned over to the Department of Parks to operate as a recreational facility. At that time the pool had lockers for 248 males and 37 females. Average monthly attendance in the mid-1930s was 20,620 and shower usage was 7,675 a month. The building underwent repairs in 1936 and again in 1977, prior to the massive reconstruction completed in 1997. Architect Bacon was known for his interest in ancient Greek architecture, and his design in 1920 for Metropolitan Pool combined functionalism with certain neo-classical details, such as the pediment on the facade. The exterior of brick with limestone trim and a granite base, however, is modest in comparison with the interior's dominant feature, a soaring skylight supported by a vaulted steel frame above the pool area. Glazed terra-cotta was used as an interior finish for the natatorium (the name applied to indoor swimming pools in the early 20th century).

Metropolitan Pool & Fitness Center contains an indoor pool, weight room, cardio room, a multi-purpose community space, as well as free classes for all of our members.

Membership Information

Youth & Teen Membership: Is FREE with access to all recreation centers, including those with indoor pools for all youth under the age of 18.

Young Adult Membership: Is \$25 for young adults ages 18 - 24 with access to all recreation centers, including those with indoor pools.

Adult Membership: Is \$150 for adults with indoor pool access (\$75 for 6 months).

Senior Membership: Is \$25 with access to all recreation centers, including those with indoor pools for all adults over 62 years old.

Veterans and People with Disabilities: Are \$25 for adults with access to all recreation centers, including those with indoor pools. **Documentation is required to register for these package categories**

NYCID Discounts: Adults ages 25-61 years of age that present a valid NYCID card at the time of registration can obtain a 10% discount off our adult 6 month and 1 year membership packages.

Membership Hours:
Sunday: 10AM—5PM
Monday to Friday: 7AM—9PM
Saturday: 7AM—4:30PM

Methods of payment for memberships are checks (no starter or business checks), money orders and debit/credit cards. All checks and money orders are to be made payable to NYCDPR.



Deputy Manager: Lawrence James
Deputy Manager: Robert Lindo

281 Bedford Ave, Brooklyn, NY 11211
(718) 599-5707
Mon—Fri 7:00a.m.–9:30 p.m.
Sat 7:00 a.m.–5:30 p.m., &
Sun 10:00 a.m.–5:30 p.m.
www.nyc.gov/parks



POOL SCHEDULE

| | |
|--------------------|-------------------------|
| Sunday | |
| Adult Lap Swim | 10:00 a.m.-12:30 p.m. |
| Aqua Boot Camp | 12:30 p.m. - 1:15 p.m. |
| General Swim | 1:15 p.m. - 2:45 p.m. |
| Women & Girls Swim | 2:45 p.m. - 4:45 p.m. |
| Monday | |
| Adult Lap Swim | 7:00 a.m. - 9:55 a.m. |
| Women's Swim | 10:00 a.m. - 11:00 a.m. |
| General Swim | 11:00 a.m. - 1:00 p.m. |
| Adult Lap Swim | 1:05 p.m. - 3:55 p.m. |
| General Swim | 4:00 p.m. - 6:30 p.m. |
| Adult Lap Swim | 6:35 p.m. - 9:15 p.m. |
| Tuesday | |
| Adult Lap Swim | 7:00 a.m. - 10:55 a.m. |
| General Swim | 11:00 a.m. - 1:00 p.m. |
| Adult Lap Swim | 2:00 p.m. - 3:55 p.m. |
| General Swim | 4:00 p.m. - 6:00 p.m. |
| Adult Lap Swim | 6:05 p.m. - 9:15 p.m. |
| Wednesday | |
| Adult Lap Swim | 7:00 a.m. - 9:00 a.m. |
| Women's Swim | 9:00 a.m.- 11:00 a.m. |
| General Swim | 11:05 a.m. - 1:00 p.m. |
| Adult Lap Swim | 1:05 p.m. - 3:55 p.m. |
| General Swim | 4:00 p.m.- 6:30 p.m. |
| Adult Lap Swim | 6:35 p.m. - 9:15 p.m. |

POOL SCHEDULE CONTINUED

| | |
|-----------------------|-------------------------|
| Thursday | |
| Adult Lap Swim | 7:00 a.m. - 10:55 a.m. |
| General Swim | 11:00 a.m. - 1:00 p.m. |
| Adult Lap Swim | 1:05 p.m. - 4:05 p.m. |
| General Swim | 4:15 p.m. - 6:00 p.m. |
| Aqua Boot Camp | 6:00 p.m.- 7:00 p.m. |
| Adult Lap Swim | 7:00 p.m. - 9:15 p.m. |
| Friday | |
| Adult Lap Swim | 7:00 a.m. - 9:55 a.m. |
| Water Exercise | 10:00 a.m. - 10:45 a.m. |
| General Swim | 11:00 a.m. - 1:00 p.m. |
| Adaptive Swim Lessons | 2:30 p.m. - 3:30p.m. |
| General Swim | 3:30 p.m. - 6:00 p.m. |
| Aqua Zumba | 6:00 p.m. - 6:45 p.m. |
| Adult Lap Swim | 7:00 p.m. - 9:15 p.m. |
| Saturday | |
| Adult Lap Swim | 7:00 a.m. - 9:55 a.m. |
| General Swim | 9:00 a.m. - 2:00 p.m. |
| Water Polo | 2:05 p.m. - 3:35 p.m. |
| Adult Lap Swim | 4:00 p.m. - 5:15 p.m. |

Indoor pool dimensions are 30 ft. wide by 75 ft. long and ranges from 3.5 ft. deep to 8.5 ft. deep.

A swimming cap is highly recommended of all swimmers.

Pool schedule is subject to change

WEIGHT ROOM: Resistance machines and free weights

CARDIO ROOM: Treadmills, Cycling Bikes, Ellipticals, & Stair Masters

AEROBICS (MULTI-USE/POLE) ROOM: Location of all the fitness programming. The room is open to members where there is no programmed classes in the room.

Members must bring a towel to use the weight, cardio, and aerobics rooms.



ADULT PROGRAMS

18 and OVER

| | |
|--|-------------------------|
| Sunday | |
| Open Aerobics Room | 10:00 a.m. - 5:30 p.m. |
| Monday | |
| Pilates | 9:00 a.m. - 10:00 a.m. |
| Small Group Exercise | 4:30 p.m. - 5:30 p.m. |
| Keep In Step with Pep | 7:00 p.m. - 7:45 p.m. |
| Tuesday | |
| Pilates | 9:00 a.m. - 10:00 a.m. |
| Tae Kwon Do | 10:30 a.m. - 11:30 a.m. |
| High Intensity Circuit Training (HICT) | 5:00 p.m. - 7:00 p.m. |
| Wednesday | |
| Pilates | 8:00 a.m. - 10:00 a.m. |
| Keep In Step | 7:00 p.m. - 7:45 p.m. |
| Thursday | |
| Pilates | 9:00 a.m. - 10:00 a.m. |
| Tae Kwon Do | 10:30 a.m. - 11:30 a.m. |
| Friday | |
| Pilates | 8:00 a.m. - 10:00 a.m. |
| RIPP/Ultimate Fitness | 3:30 p.m. - 5:00 p.m. |

YOUTH & TEEN PROGRAMS

| | |
|-----------------------|------------------------|
| Monday | |
| Learn To Play Chess | 3:00 p.m. - 4:30 p.m. |
| Art for Beginners | 3:00 p.m. - 4:30 p.m. |
| Keep In Step with Pep | 7:00 p.m. - 7:45 p.m. |
| Tuesday | |
| Learn To Play Chess | 3:00 p.m. - 4:30 p.m. |
| Art for Beginners | 3:00 p.m. - 4:30 p.m. |
| Tae Kwon Do | 4:30 p.m. - 5:30 p.m. |
| Wednesday | |
| Learn To Play Chess | 3:00 p.m. - 4:00 p.m. |
| Art for Beginners | 3:00 p.m. - 4:00 p.m. |
| Tae Kwon Do | 4:00 p.m. - 5:00 p.m. |
| Keep In Step | 7:00 p.m. - 7:45 p.m. |
| Thursday | |
| | |
| Friday | |
| RIPP/Ultimate Fitness | 3:30 p.m. - 5:00 p.m. |
| Tae Kwon Do | 5:00 p.m. - 6:00 p.m. |
| Saturday | |
| Tae Kwon Do | 8:30 a.m. - 9:45 a.m. |
| Tae Kwon Do | 12:00 p.m. - 2:00 p.m. |



***Item Acquired Via Purchase Order Submittals 7/1/2019**

| NAME | AMOUNT | CODE | DATE |
|----------------------------------|---------------|-------------|-----------------|
| Accelerated Technologies | \$264.00 | 319 | 7/1/19- 6/30/20 |
| Konica Minolta Business Solution | \$1,356.72 | 412 | 7/1/19- 6/30/20 |
| DS Services of America Inc. | \$63.90 | 110 | 7/1/19- 6/30/20 |
| The Chief | \$33.00 | 337 | 7/1/19- 6/30/20 |
| Verizon Wireless | \$1,122 | 402 | 7/1/19- 6/30/20 |
| Neopost | \$359.40 | 431 | 7/1/19- 6/30/20 |
| Rent (435 Graham Avenue) | \$66,543.00 | 414 | 7/1/19- 6/30/20 |
| Intercity Telephone | \$2, 256.00 | 40B-856 | 7/1/19- 6/30/20 |
| Intercity Storehouse | \$300.00 | 10X | 7/1/19- 6/30/20 |
| Intercity Auto Fuel | \$200.00 | 106 | 7/1/19- 6/30/20 |



District Manager's Report Community Board No. 1 Brooklyn

TO: All Board Members

**FROM: Gerald A. Esposito
District Manager**

RE: June 11, 2019

1. Complaint Tally Sheet for May 2019.
2. New York City Equal Employment Practices Commission RE: Determination of Compliance for CB#1, Resolution # 2019AP/230-471.
3. New York City Department of Youth & Community Development RE: The Meeting Neighborhood Advisory Board Brooklyn 1, will occur on Wednesday, June 12 2019 at 6:00 PM. The Meeting will be held at El Puente, 211 South 4th Street, Brooklyn.
4. NYD PBBN 5K Walk, Run and Wheel on Saturday June 22, 2019 at 10:00 AM.
5. Community Board No. 1's Lease for its Office at 435 Graham Avenue has the following term: November 28, 2005 to July 31, 2020. The lease is under the auspices of DCAS (Department of City Wide Administrative Services). At the current time, DCAS is directly negotiating a lease renewal. Our Board has no role in these Discussions.
6. Churches United for Fair Housing (CUFFH) for Immediate Release: "Breaking! Public Advocate Williams To Introduce Racial Impact Study Requirement In City Rezoning Process"
7. New York City Transit RE: Implementation of 3, 4, 5, Subway Schedule Revisions in November 2019.
8. New York State Department of Environmental Conservation Notice of Complete Application RE: Greenpoint Landing Building H3, 1Bell Slip, Brooklyn, NY 11222.
9. CB#1 Form for "Request To Be On Our Mailing List Via Email"
10. Kosciuszko Bridge Bikeway/Walkway Questions & Answers between Gerry & NYSDOT:
 - Hours---24/7
 - Width of travel lane ---- 20'
 - Delineation between Bikeway/Walkway--- Painted Surface
 - 9' fence for overlook
 - No Benches
 - Trash receptacles--- yes maintained by DSNY
 - *Unconfirmed by DSNY
 - NYPD patrolled – 94/108 Precincts
 - * Unconfirmed by NYPD
11. New List Board Member Appointments/Reappointments from the Brooklyn Borough President, Eric L. Adams.



COMMUNITY BOARD NO. 1
435 GRAHAM AVENUE – BROOKLYN, NY 11211

PHONE: (718) 389-0009

FAX: (718) 389-0098

Email: bk01@cb.nyc.gov

Website: www.nyc.gov/brooklyn1

HON. ERIC L. ADAMS
BROOKLYN BOROUGH PRESIDENT



SIMON WEISER
 FIRST VICE-CHAIRMAN
DEL TEAGUE
 SECOND VICE-CHAIRPERSON
STEPHEN J. WEIDBERG
 THIRD VICE-CHAIRMAN
MARIA VIERA
 FINANCIAL SECRETARY
SONIA IGLESIAS
 RECORDING SECRETARY
PHILIP A. CAPONEGRO
 MEMBER-AT-LARGE

DEALICE FULLER
 CHAIRPERSON
GERALD A. ESPOSITO
 DISTRICT MANAGER

HON. STEPHEN T. LEVIN
 COUNCILMEMBER, 33rd CD
HON. ANTONIO REYNOSO
 COUNCILMEMBER, 34th CD

June 11, 2019

TO: ALL BOARD MEMBERS
FROM: GERALD A. ESPOSITO, DISTRICT MANAGER
RE: COMPLAINT TALLY SHEET – MAY 2019

| | TALLY | |
|-----------------------|-------|------------------------|
| DEP | 3 | |
| AIR | 3 | |
| NOISE | 2 | |
| WATER | | |
| SEWER BREAK | | |
| SEWER BACKUP | | |
| CATCH BASIN | 2 | |
| HYDRANT | 1 | |
| DOS | | |
| DERELICT AUTO/BIKES | 1 | |
| BULK PICKUP | 1 | |
| REGULAR PICKUP | 4 | |
| LOT CLEANING | 1 | |
| UNSWEPT STREET LITTER | 3 | |
| SNOW REMOVAL | | |
| ENFORCEMENT | 4 | |
| BASKET REQUESTS | 1 | |
| SIGNS | 1 | |
| RECYCLING | 2 | |
| HEALTH DEPT | | |
| PEST CONTROL | 2 | |
| LOT CLEANING | | |
| ASSISTANCE | 1 | |
| DOCUMENTS | 1 | birth certificate info |
| HOUSING AUTHORITY | | |
| APPLICATION | 1 | |
| SERVICE | 1 | |
| ELEVATOR | | |
| OTHER | | |
| SENIOR HOUSING | 1 | info |
| FIRE DEPT | | |
| SERVICE | 1 | |
| EQUIPMENT | 1 | |
| ANIMAL CONTROL | | |
| HPD | | |
| SEAL-UP | | |
| DEMO | 1 | info |
| HEAT/HOT WATER | | |
| CODE ENFORCE. | 2 | information |
| RELOCATION | | |
| RENT CONTROL | | |
| OTHER | 1 | information |
| BUILDINGS DEPT | 6 | info and complaints |
| REFERRALS | | |
| LEGAL | 1 | |
| STATE | 2 | |
| FEDERAL | 2 | Post Office |

| | | |
|---------------------|------------|-----------------------|
| NATIONALGRID | 2 | Repair work in street |
| EDUCATION | | |
| SCHOOL REGION | | |
| SCHOOL PS | | |
| JHS | | |
| HS | | |
| COLLEGE | | |
| OTHER | 1 | School request |
| HRA | | |
| SOCIAL SERVICES | 1 | referral |
| MEDICAID | | |
| PUBLIC ASSISTANCE | | |
| FOOD STAMPS | | |
| OTHER | 2 | |
| DCAS | 1 | info |
| REAL ESTATE | 1 | city owned property |
| PARKS DEPT | | |
| TREE REQUESTS | | |
| TREE REMOVAL | | |
| PRUNING | 1 | |
| SPRAYING | | |
| POOLS | | |
| GREENSTREET | | |
| PARKS | 3 | |
| POLICE DEPT. | | |
| PROTECTION | 5 | |
| DRUGS | 1 | |
| PARKING | 10 | illegal parking |
| CRIME | 1 | |
| MTA | | |
| DOT | | |
| HIGHWAYS | | |
| POT HOLES | | |
| PLATES | 1 | stored on street |
| SIDEWALK | 2 | obstructions |
| CAVE-IN | | |
| METERS | | |
| SIGNS | 1 | request for sign |
| TRAFFIC LIGHTS | | |
| TRENCH WORK (& DEP) | | |
| STREET LIGHT | | |
| CON EDISON | | |
| INFO REQUESTS | 398 | |
| VERIZON/CABLE | | |
| DCA | 1 | sidewalk café |
| LICENSE | 1 | Inquiry |
| ARCADE/RIDES | | |
| OTHER | | |
| TOTAL | 480 | |

Respectfully submitted,
Marie Bueno Wallin
 Assistant District Manager



**Equal Employment
Practices Commission**

BY MAIL AND EMAIL

Vacant
Chair

May 21, 2019

Angela Cabrera
Malini Cadambi Daniel
Elaine S. Reiss, Esq.
Arva R. Rice
Commissioners

Dealice Fuller
Chairperson
Brooklyn Community Board No. 1
435 Graham Avenue
Brooklyn, NY 11211

Charise L. Terry, PHR
Executive Director

19 MAY 21 3:46 PM

Judith García Quiñonez, Esq.
Executive Agency Counsel/
Director of Learning and Development

Re: Resolution #2019AP/230-471-(2019)C11
DETERMINATION: Compliance

Jennifer Shaw, Esq.
Executive Agency Counsel/
Director of Compliance

Dear Chairperson Fuller:

253 Broadway
Suite 602
New York, NY 10007

212. 615. 8939 tel.
212. 676. 2724 fax

On behalf of the members of the Equal Employment Practices Commission (EEPC), I write to inform you that pursuant to New York City Charter Chapter 35, Sections 815(a)(15) and (19), which requires agency heads to ensure and promote equal opportunity for all persons in appointment, payment of wages, development, and advancement, and to establish measures and programs to ensure a fair and effective affirmative employment plan to provide equal employment opportunity (EEO) for minority group members and women, the EEPC's Board of Commissioners has approved the attached Determination.

Thank you and District Manager Esposito for the cooperation extended to the EEPC during the course of our review, evaluation, and monitoring of your agency's employment and EEO-related practices.

Sincerely,

Arva R. Rice
Commissioner

C: Gerald A. Esposito, District Manager, Brooklyn Community Board No. 1



**Equal Employment
Practices Commission**

**RESOLUTION NO.
2019AP/230-471-(2019)C11
Brooklyn Community Board No. 1
Chairperson Dealice Fuller
Sexual Harassment Prevention and Response Practices Audit
DETERMINATION: COMPLIANCE**

SYNOPSIS

| | | | |
|---|--------------------------------------|-------------------|-------------|
| Corrective Action(s) | Total: 0 | | |
| Period Audit Covered | January 1, 2018 to December 31, 2018 | | |
| Preliminary Determination Issued | May 3, 2019 | Response Received | May 6, 2019 |
| Final Determination Issued | May 10, 2019 | Exempt | |
| Compliance-Monitoring | Not Required | | |

Whereas, pursuant to Chapter 36, Sections 830(a) and 831(d)(2) and (5) of the New York City Charter (Charter), the Equal Employment Practices Commission (EEPC) is authorized to audit, review, evaluate, and monitor the employment procedures, practices and programs of city agencies and other municipal entities (hereinafter "entities") and their efforts to ensure fair and effective equal employment opportunity (EEO) for minority group members and women who are employed or seek employment, and to recommend practices, procedures, approaches, measures, standards, and programs to be utilized by such entities in these efforts; and

Whereas, pursuant to Charter Chapter 36, Sections 830(a) and 831(d)(2) and (5), the EEPC has adopted uniform standards for auditing agencies and municipal entities, and minimum standards for auditing community boards, to review, evaluate, and monitor entities' practices, procedures, approaches, measures, standards, and programs for compliance with federal, state, and local laws and regulations, and policies and procedures to increase equal opportunity for women, minorities, and other employees and job applicants identified for protection from discrimination; and

Whereas, in accordance with Charter Chapter 36, Section 832(c), the EEPC may make a determination pursuant to Charter Section 831(d) whether any plan, program, procedure, approach, measure, or standard adopted or utilized by any municipal entity does not provide equal employment opportunity, and the EEPC's determinations of compliance or non-compliance and prescribed corrective action are required by, or consistent with federal, state, and local laws and regulations, and policies and procedures to increase equality of opportunity for women, minorities, and other employees and job applicants identified for protection from discrimination; and

Whereas, the EEPC conducted an audit, review, and evaluation of the Brooklyn Community Board No. 1's Sexual Harassment Prevention and Response Practices; and

Whereas, pursuant to the audit, review, and evaluation of the Brooklyn Community Board No. 1's Sexual Harassment Prevention and Response Practices, the EEPC issued a Preliminary Determination, dated May 3, 2019, setting forth findings; and

Whereas, within a two-week deadline following the EEPC's Preliminary Determination, the entity submitted a preliminary response; and

Whereas, in accordance with Charter Chapter 36, Section 832(c), after consideration, the EEPC issued a Final Determination on May 10, 2019, which indicated that no areas required corrective action; and

Whereas, in accordance with Charter Chapter 36, Section 832(c), in the Final Determination, the EEPC assigned a monitoring period from June 1, 2019 to July 31, 2019, to determine whether the entity eliminated areas of non-compliance, if any; and

Whereas, in accordance with Charter Chapter 36, Section 832(c) the entity was required to respond in 30 days, and make monthly reports thereafter for a period not to exceed six months, on the progress of its efforts to correct outstanding areas of non-compliance; and

Whereas, in accordance with Charter Chapter 36, Section 832(c), on May 10, 2019, the entity was exempt from issuing a response to the EEPC's Final Determination; and

Whereas, in accordance with Charter Chapter 36, Section 832(c), the Brooklyn Community Board No. 1 was exempt from monitoring on May 10, 2019; and

Whereas, pursuant to Charter Chapter 35, Sections 815(a)(15) and (19), which requires agency heads to ensure and promote equal opportunity for all persons in appointment, payment of wages, development, and advancement, and to establish measures and programs to ensure a fair and effective affirmative employment plan to provide equal employment opportunity for minority group members and women, the Chairperson submitted a copy of a memorandum to staff dated May 6, 2019, which recognized the EEPC's audit and reiterated commitment to the Brooklyn Community Board No. 1's equal employment practices; Now Therefore,

Be It Resolved, that the Brooklyn Community Board No. 1 has satisfied the equal employment standards set by the EEPC pursuant to its authority under New York City Charter Chapters 35 and 36; and

Be It Resolved, that the EEPC's Board of Commissioners approves the issuance of this Determination of Compliance to Chairperson Dealice Fuller of the Brooklyn Community Board No. 1.

Approved unanimously on May 21, 2019.



Angela Cabrera
Commissioner

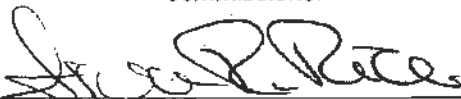

Arva R. Rice
Commissioner

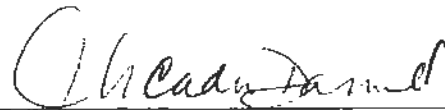

Malini Capambi Daniel
Commissioner

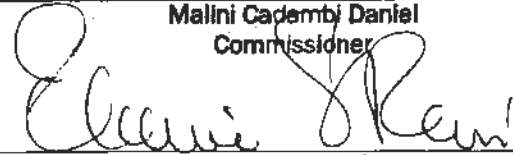

Elaine S. Reiss, Esq.
Commissioner

This

Determination of Compliance

is hereby issued to

Brooklyn Community Board No. 1

*for successful implementation of 1 of 1 required corrective action(s),
thereby achieving compliance with the Equal Employment Practices Commission's
Sexual Harassment Prevention and Response Practices Audit
from January 1, 2018 to this date.*

On this 21 day of May in the year 2019



Arva R. Rice, Commissioner



Charise L. Terry, Executive Director

In care of Chairperson Dealice Fuller
and District Manager Gerald A. Esposito



NEW YORK CITY
DEPARTMENT OF YOUTH AND COMMUNITY DEVELOPMENT
SERVING NEW YORK CITY YOUTH, FAMILIES, AND COMMUNITIES

123 William Street
New York, New York 10038
Phone 646.343.6000 Fax 212.442.5998
www.nyc.gov/dycd

BILL CHONG
Commissioner

May 22, 2019

Mr. Gerald A. Esposito
District Manager
435 Graham Avenue
Brooklyn, NY 11211

Dear Mr. Esposito:

The meeting of Neighborhood Advisory Board Brooklyn 1, will occur on Wednesday, June 12, 2019 at 6:00pm. The meeting will be held at El Puente, 211 South 4th Street, Brooklyn, NY 11217.

The proposed agenda for the aforementioned meeting will include:

Update on CNA
Activities and Locations For CNA
National Night Out
Old Business
New Business

Should you require additional information, please feel free to contact me at (646) 343-6499.

Sincerely,

A handwritten signature in black ink that reads "Jeff Kohn". The signature is written in a cursive style.

Jeff Kohn, Liaison
NAB/CAB Liaison Unit



Reply all | Delete | Junk | ...

NYPD PBBN 5K WALK, RUN AND WHEEL

P PBBNCO <PBBNCO@nypd.org>
Today, 4:45 PM

Reply all |

Inbox



DP5K Photo.pdf
1 MB



Show all 2 attachments (6 MB) Download all Save all to OneDrive - NYC O365 HOSTED

Good Afternoon,

On Behalf of the NYPD and Patrol Borough Brooklyn North, I would like to invite you to Patrol Borough Brooklyn North's 2nd 5K Run, Walk, Wheel to support and raise awareness for children with disabilities. The run will take place on Saturday June 22, 2019 at Domino park in Williamsburg Brooklyn with race time starting at 10:00AM.

The run started in an effort to help Police officers who have children with disabilities or terminal illness to show them we support them through their struggles and are there to help them. The Proceeds will go to a non profit organization called NYPD With Arms Wide Open which helps families foot some of the medical bills and items they may need as well as a support network.

Of the **40,000** members of the New York City Police Department, it is estimated that nearly **5,000** members have a child with special needs. In addition to the daily stresses associated with protecting and serving the city, those with special needs children have to deal with added financial, emotional and physical challenges. The 5k is intended to not only raise funds for these families but provide a platform that embodies support for these families throughout the entire police department and beyond. 100% of the profits from this event will be donated to an organization that assist the men and women of the NYPD with their children that have special needs. That wonderful organization is known as **WITH ARMS WIDE OPEN**.

This years Grand Marshall is Sophia Bartley, Daughter of 67 Precinct Sergeant Brian Bartley who suffers from a rare terminal illness called Ataxia Telangiectasia.

Our website is www.pbbn5k.com where there's more details on the race including options to buy tickets and or donations. Current Price if purchased prior to race day is \$40 a person which includes a shirt, bib and

 Reply all |   Delete  Junk |  

As Prominent members in our communities we would love for your support and attendance if your schedule permits. Attached is a flyer if you can help post and share to your community to help spread the word.

Thank you,

Assistant Chief Jeff Maddrey
Commanding Officer, Patrol Borough Brooklyn North



For Immediate Release:

May 29, 2019

Contact: Alex Fennell, afennell@cuffh.org, (404) 368-3610

**PUBLIC ADVOCATE JUMAANE WILLIAMS TO INTRODUCE LEGISLATION
TO REQUIRE STUDY OF HOW REZONINGS IMPACT RACIAL
DEMOGRAPHICS AND FAIR HOUSING**

NEW YORK, NY (Wednesday, May 29, 2019) - This morning, Public Advocate Jumaane Williams, alongside Churches United for Fair Housing staff, announced at a press conference that he will introduce new legislation that would include a racial impact analysis as part of the City's environmental impact study. Jointly introduced with City Council Member Rafael Salamanca, the proposed amendment to the City's Administrative Code would add a section specifically to address the racial impacts of land use actions, studying how rezoning plans impact the racial makeup of neighborhoods. The legislation would require all draft and final environmental impact statements to include analysis of both direct and indirect racial and ethnic residential impacts of proposed rezoning and development projects and would require the analysis to indicate whether the proposed project affirmatively furthers fair housing, as defined and required by the Fair Housing Act.



For the last decade, Churches United for Fair Housing (CUFFH) has been fighting for fair housing at the Broadway Triangle in Brooklyn. This past January, CUFFH staff and community leaders were joined by then Council Member Jumaane Williams, as well as other federal, state and local elected officials, Brooklyn Legal Services Corporation A, members of St. John the Evangelist Lutheran Church and north Brooklyn residents, to announce the launch of CUFFH's Racial Impact Study campaign. The campaign aims to combat racial segregation that is caused by City rezonings. After connecting the history of rezonings, especially the 2005 Williamsburg waterfront rezoning, with increased harassment, evictions, displacement and ultimately, racial segregation, the campaign was designed to point to the urgent need for the City to acknowledge the impact of its decisions. CUFFH proposed the addition of a Racial Impact Study (RIS) to the environmental impact study, already required during the rezoning process, an idea which then Council Member Jumaane Williams pledged to push forward when elected to the office of NYC Public Advocate.

"As I was running for Public Advocate, I met with advocacy groups including CUFFH, which had an amazing idea that would aid in issues with rezoning. Rezoning have had a net effect of speeding up gentrification. If people are going to be gentrified out, that should be paid attention to and studied." — NYC Public Advocate, Jumaane Williams

"The Racial Impact Study is the first step in undoing the harm caused by over a century of land use policy rooted first in overt racism and then shielded by color-blind language. If we do not confront racialized displacement head on, it is certain to continue just as it has in every rezoning we have seen in a low-income community of color. This legislation has the opportunity to be a powerful tool, to promote access to opportunity and affirmatively further fair housing, and CUFFH is excited to be part of introducing this bill today." — Alexandra Fennell, Network Director, CUFFH

"A Racial Impact Study is not only badly needed to address segregative rezonings in this city, but it is also required under the Fair Housing Act. Our communities of North Brooklyn have been demanding this for the last decade. We are glad that Public Advocate Jumaane Williams has introduced the legislation today. It is a critical step in the struggle to stop the displacement and gentrification of neighborhoods of color." — Shekar Krishnan, Director of Legal Advocacy, Brooklyn Legal Services Corporation A



New York City Transit

May 24, 2019

Mr. Gerald A. Esposito
District Manager - Community Board No.1
435 Graham Avenue
Brooklyn, NY 11211

Re: Implementation of 3 4 5 Subway Schedule Revisions in November 2019

Dear Mr. Esposito:

I am writing to inform you that NYC Transit will be making changes to some evening and late-night schedules on the 3 4 5 subway lines in November 2019, to accommodate the rigorous maintenance, repair, and construction projects associated with the Subway Action Plan and other efforts to improve service, while also ensuring that we can operate the best service possible for our customers while this essential work is underway.

As you know, NYC Transit has been working intensively over the past two years to improve the reliability of the service we provide to our customers. This work includes cleaning tens of thousands of grates and drains, sealing thousands of leaks, repairing or replacing miles of track, removing tons of debris, and rebuilding thousands of signal components. Our most recent statistics show continued dramatic improvement in subway performance, with the highest on-time performance numbers in more than half a decade. This demonstrates that the State and City's substantial investment in infrastructure and maintenance improvements under the Subway Action Plan are yielding remarkably positive results, and illustrates the rewards of the planned service changes.

Subway on-time performance for April reached its highest level since October 2013—nearly 80 percent. In addition, major incidents decreased 32 percent from last April, matching the fewest since measurement began in 2015. Furthermore, weekday delays decreased 35 percent from last April, reaching the lowest level since December 2013. One of the contributing factors to the reduction in subway delays has been the significant progress made in reducing track debris fires. Year-to-date track fires have dropped by 52 percent compared to 2018.

As much of our repair, upgrade, and intensified maintenance activities are performed during evening and late-night hours, we are seeking to maximize the productivity of our workforce during those times. This necessitates adjustments in our operations to accommodate the unprecedented level of work that is underway.

The schedule adjustments we will be implementing on the ③④⑤ lines are necessary to make changes in the span of weekday evening service to facilitate track replacement, signal and power cable upgrades, and drain cleaning that requires transitioning to the overnight service pattern earlier than currently scheduled in the base timetables. These changes—already implemented regularly via temporary schedules most weeknights—will help customers plan ahead with a stable and reliable schedule. Implementing this package of schedule changes will incorporate the revisions in our base timetables, making these service changes more efficient and less costly, and providing more consistent evening and late-night service for our customers.

We have outlined basic information about these schedule adjustments below:

- Five ③ line roundtrips, operating on weekdays from approximately 10:30 p.m. to 11:30 p.m. between Harlem-148 St and New Lots Ave, will change to operations between Harlem-148 St and Times Square. Service to and from New Lots Ave during these times will be delivered by the ④ line.
- Four ④ line roundtrips, operating on weekdays from approximately 10:30 p.m. to 11:30 p.m. between Woodlawn and Crown Heights-Utica Ave, will extend to operations between Woodlawn and New Lots Ave.
- Five ⑤ line roundtrips, operating weekdays from approximately 10:00 p.m. to 11:00 p.m. between Eastchester-Dyre Ave and Bowling Green, will be replaced by four roundtrips between Eastchester-Dyre Ave and E 180 St. Customers traveling between Manhattan and E 180 St may take the ② line and connecting services.

This subway schedule revision package will be presented to the NYC Transit and Bus Committee of the MTA Board on Monday, June 24, 2019 at 10:00 a.m. in the 20th floor boardroom at 2 Broadway. Speaker registration will be conducted during the 15-minute period preceding the start of the meeting.

Implementation of 345 Subway Schedule Revisions in November 2019

May 24, 2019

Page 3

If you have questions, require any additional information, or if you would like to confirm the date of the meeting at which this matter will be reviewed, please have a member of your staff contact Robert Marino, Acting Vice President for Government and Community Relations, at 646-252-2660.

Sincerely,

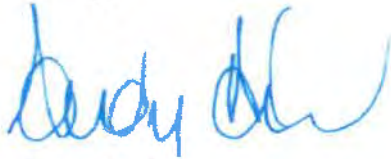

Andy Byford
President

cc: Max Young
Sarah Meyer
Sally Librera
Judith McClain
Robert Marino

THIS IS NOT A PERMIT

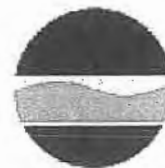

**New York State Department of Environmental Conservation
Notice of Complete Application**

Date: 05/17/2019

Applicant: BOP GREENPOINT H-3 LLC
250 VESEY ST FL 15
NEW YORK, NY 10281

Facility: GREENPOINT LANDING BUILDING H3
1 Bell Slip
Brooklyn, NY 11222

Application ID: 2-6101-01392/00001

Permits(s) Applied for: 1 - Article 17 Titles 7 & 8 Industrial SPDES - Surface Discharge

Project is located: in KINGS COUNTY

Project Description:

The Department has made a tentative determination to approve this application for a new permit for a proposed discharge of up to 432,000 gallons per day of treated groundwater into Newtown Creek (Class SD) via an on-site outfall from a treatment system consisting of sedimentation, filtration and carbon adsorption at the applicant's project site located at 1 Bell Slip in Brooklyn where the applicant will temporarily dewater to facilitate construction of a new multi-story residential tower with cellar. The draft permit and fact sheet may be viewed and printed from the Department web site at: <http://www.dec.ny.gov/permits/6054.html>. Refer to this application by the SPDES Number NY0276987.

Availability of Application Documents:

Filed application documents, and Department draft permits where applicable, are available for inspection during normal business hours at the address of the contact person. To ensure timely service at the time of inspection, it is recommended that an appointment be made with the contact person.

State Environmental Quality Review (SEQR) Determination

Project is a Type I action and will not have a significant effect on the environment. A coordinated review with other involved agencies was performed and a Negative Declaration is on file.

SEQR Lead Agency NYC Planning Commission

State Historic Preservation Act (SHPA) Determination

A cultural resources survey has been completed and cultural resources were identified. Based on information provided in the survey report, the New York State Office of Parks, Recreation and Historic Preservation (OPRHP) has determined that the proposed activity will have no adverse impact on registered or eligible archaeological sites or historic structures. No further review in accordance with SHPA is required.

Coastal Management

This project is located in a Coastal Management area and is subject to the Waterfront Revitalization and Coastal Resources Act.

DEC Commissioner Policy 29, Environmental Justice and Permitting (CP-29)

It has been determined that the proposed action is not subject to CP-29.

Availability For Public Comment

Comments on this project must be submitted in writing to the Contact Person no later than 06/21/2019 or 30 days after the publication date of this notice, whichever is later.

Contact Person

Caitlyn P Nichols
NYSDEC
47-40 21st St
Long Island City, NY 11101-5401
(718) 482-4997

CC List for Complete Notice

ENB

IF YOU ARE INTERESTED IN RECEIVING
MEETING NOTICES VIA E-MAIL US
bk01@cb.nyc.gov

NAME: _____

ADDRESS: _____

PHONE: _____

E-MAIL: _____

THANK YOU FOR YOUR COOPERATION

THANK YOU



OFFICE OF THE BROOKLYN BOROUGH PRESIDENT

Community Board 1
435 Graham Avenue
Brooklyn, New York 11211
(718) 389-0009

19 JUN 5 9:02

Chairperson: Dealice Fuller

District Manager: Gerald A. Esposito

Council Members: Stephen Levin (33), Antonio Reynoso (34)

Expires March 31, 2020

Expires March 31, 2021

| | | | |
|-----------------------------|------|------------------------------|-------------|
| 1. Michael Gary Schlesinger | (BP) | 26. Toby Moskovits | (BP) |
| 2. Vincent Gangone | (BP) | 27. Bogdan Bachorowski | (BP) |
| 3. Stephen Weidberg | (BP) | 28. James Stuart | (BP) |
| 4. Del Teague | (BP) | 29. Julia Amanda Foster | (BP) |
| 5. David Niederman | (BP) | 30. Joel Gross | (BP) |
| 6. Joshua Cohen | (BP) | 31. Bozena Kaminski | (BP) |
| 7. Tommy Torres | (BP) | 32. Yoel Landau | (BP) |
| 8. Isaac Sofer | (BP) | 33. Philip Caponegro | (BP) |
| 9. Louis Barricelli | (BP) | 34. Gina Argento | (BP) |
| 10. Emily Gallagher | (BP) | 35. Yoel Low | (BP) |
| 11. Dana Rachlin | (BP) | 36. Lisa Bamonte | (BP) |
| 12. Moishe Indig | (BP) | 37. Dealice Fuller | (BP) |
| 13. Mary Odomirok | (33) | 38. Michael Chirichella | (BP) |
| 14. Theresa Cianciotta | (33) | 39. Maria Viera | (33) |
| 15. Solomon Green | (33) | 40. Trina McKeever | (33) |
| 16. Frank Carbone | (33) | 41. Arthur Dybanowski | (33) |
| 17. T. Willis Elkins | (33) | 42. Simon Weiser | (33) |
| 18. Ryan Kuonen | (33) | 43. Avrom Katz | (33) |
| 19. Stephen Chesler | (33) | 44. William Klagsbald | (33) |
| 20. Janice Peterson | (34) | 45. Joel Goldstein | (33) |
| 21. Iris Minaya Cabrera | (34) | 46. Karen Nieves | (34) |
| 22. Marie Leanza | (34) | 47. Thomas Burrows | (34) |
| 23. Eric Bruzaitis | (34) | 48. Giovanni D'Amato | (34) |
| 24. Robert Solano | (34) | 49. Sonia Iglesias | (34) |
| 25. Martin Needelman | (34) | 50. Gina Barros | (34) |

Stephen Ringel - BH Liaison
BOLD - New appointment