

Example Diagram 1:
Service Disconnecting Means at each
Cogeneration Engine.
(Twenty Services and Twenty Service
Disconnecting Means)

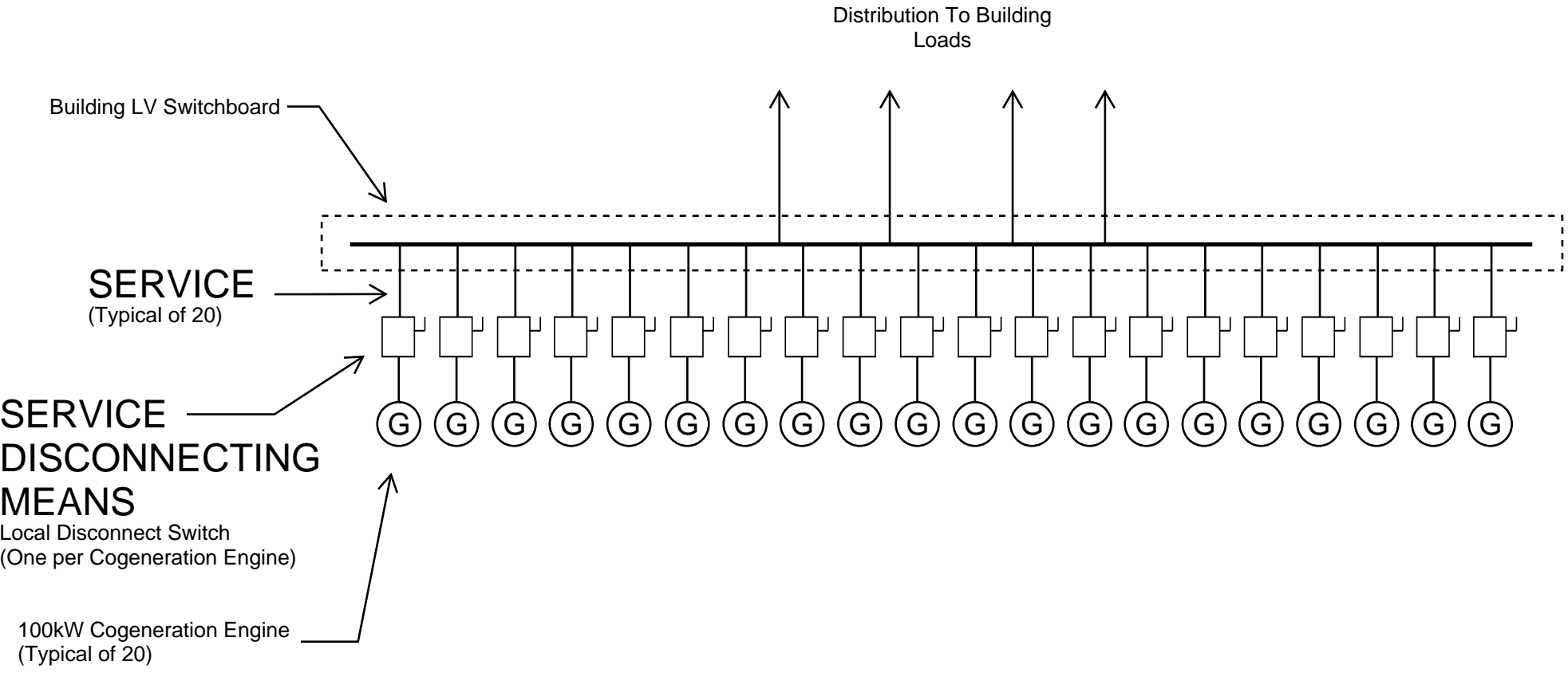

Example Diagram 2:

Service Disconnecting Means at each Cogeneration Engine.

(Twenty Services and Twenty Service Disconnecting Means. Grouped in quantities of fewer than six.)

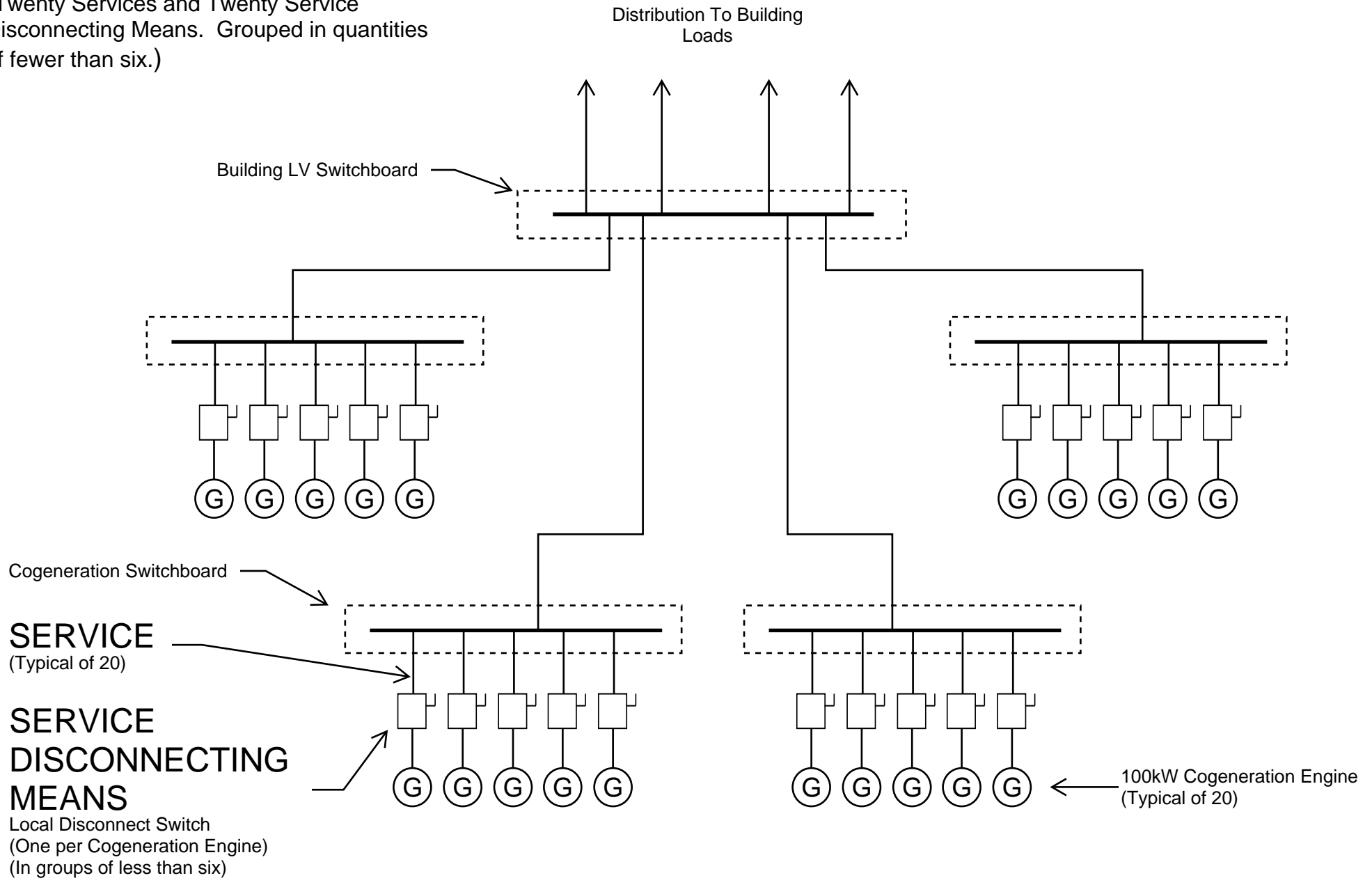

Example Diagram 3:
Service Disconnecting Means at
Output of each Cogeneration Engine
Switchboard
(Four Services and Four Service
Disconnecting Means)

