

Madewell

69 GANSEVOORT

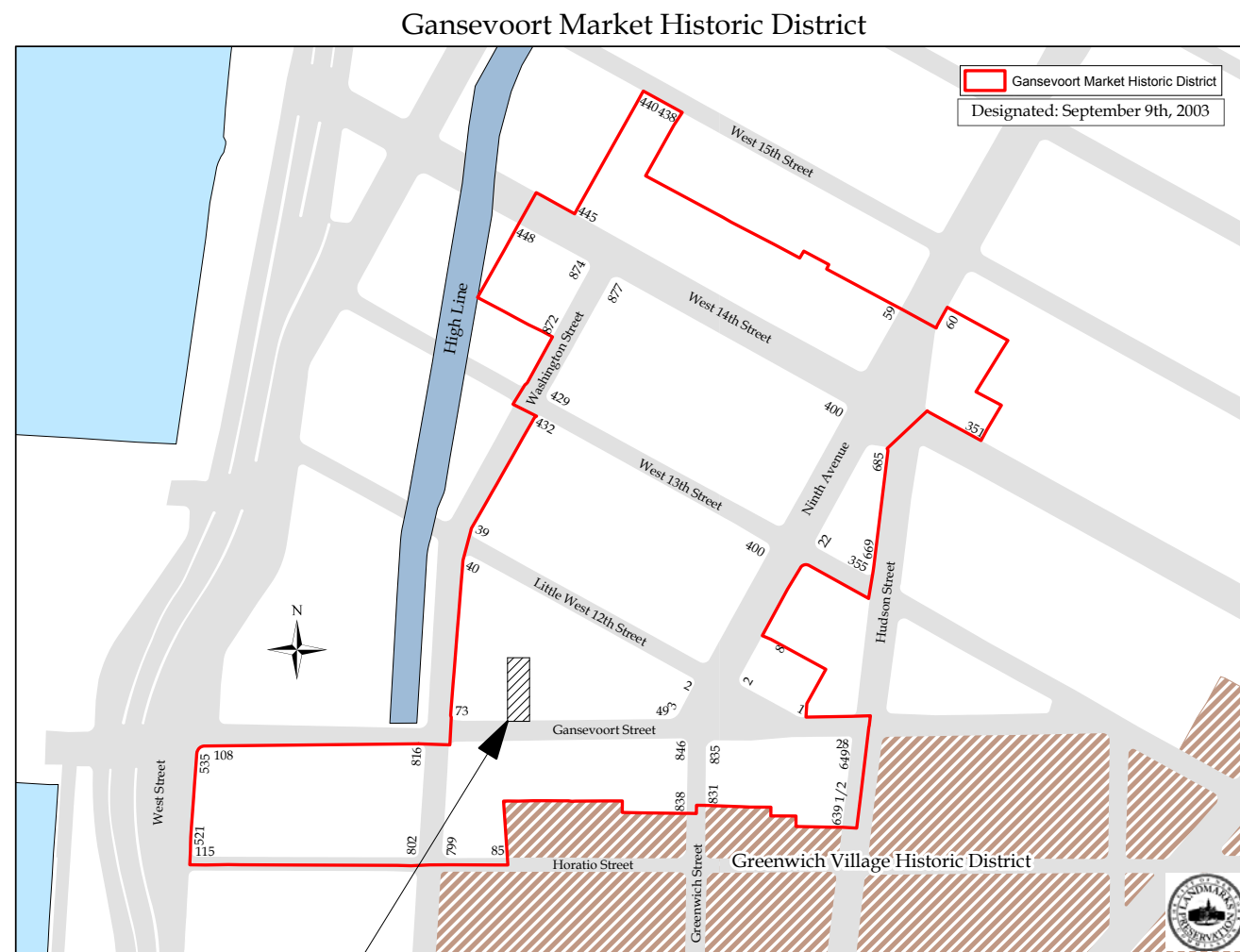

MADWELL, 69 GANSEVOORT,
NEW YORK, NY 10014

BLOCK: 644, LOT: 64
ZONING MAP: 8B, ZONE: M1-5

DRAWING LIST

- | | |
|-----|--------------------------------------|
| A-1 | Cover Sheet |
| A-2 | Tax Photos |
| A-3 | Existing Storefront Photos |
| A-4 | Existing & New Storefront Photos |
| A-5 | Existing & New Storefront Plans |
| A-6 | Existing & New Storefront Elevations |
| A-7 | Blade Sign |
| A-8 | Tax Photos & New Storefront |

Lalire March Architects LLP

304 Hudson Street 6 fl
New York New York 10013
212 807 1011

LalireMarchArchitects

Madewell

69 Gansevoort Street
New York, NY 10014
11/16/16

Cover Sheet

A-1



TAX PHOTO - 1940



TAX PHOTO - 1980

Lalire March Architects LLP
304 Hudson Street 6 fl
New York New York 10013
212 807 1011
LalireMarchArchitects

Madewell

69 Gansevoort Street
New York, NY 10014
11/16/16

Tax Photos



EXISTING STOREFRONT

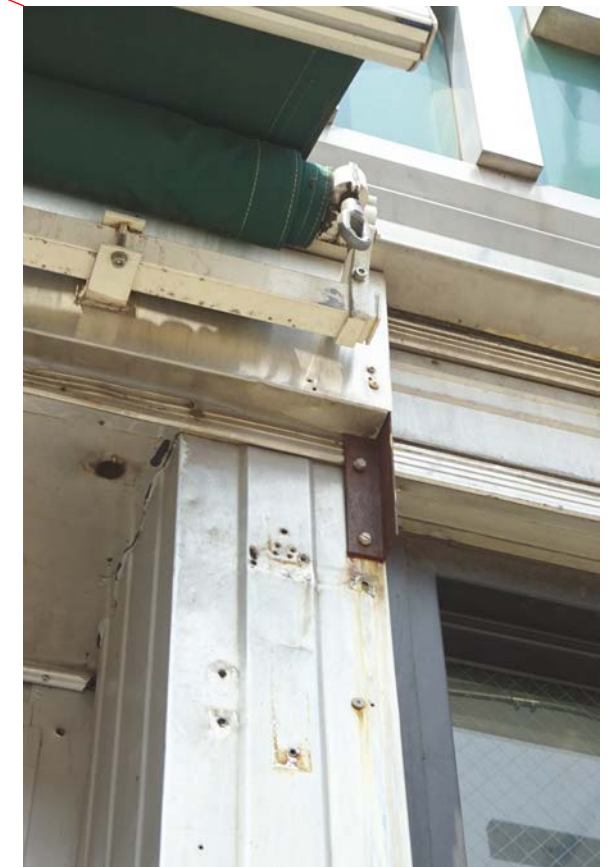

Lalire March Architects LLP
304 Hudson Street 6 fl
New York New York 10013
212 807 1011
LalireMarchArchitects

Madewell
69 Gansevoort Street
New York, NY 10014
11/16/16
Existing Storefront



EXISTING STOREFRONT



NEW STOREFRONT

Lalire March Architects LLP
304 Hudson Street 6 fl
New York New York 10013
212 807 1011

LalireMarchArchitects Existing & New Storefront Photos

Madewell
69 Gansevoort Street
New York, NY 10014
11/16/16

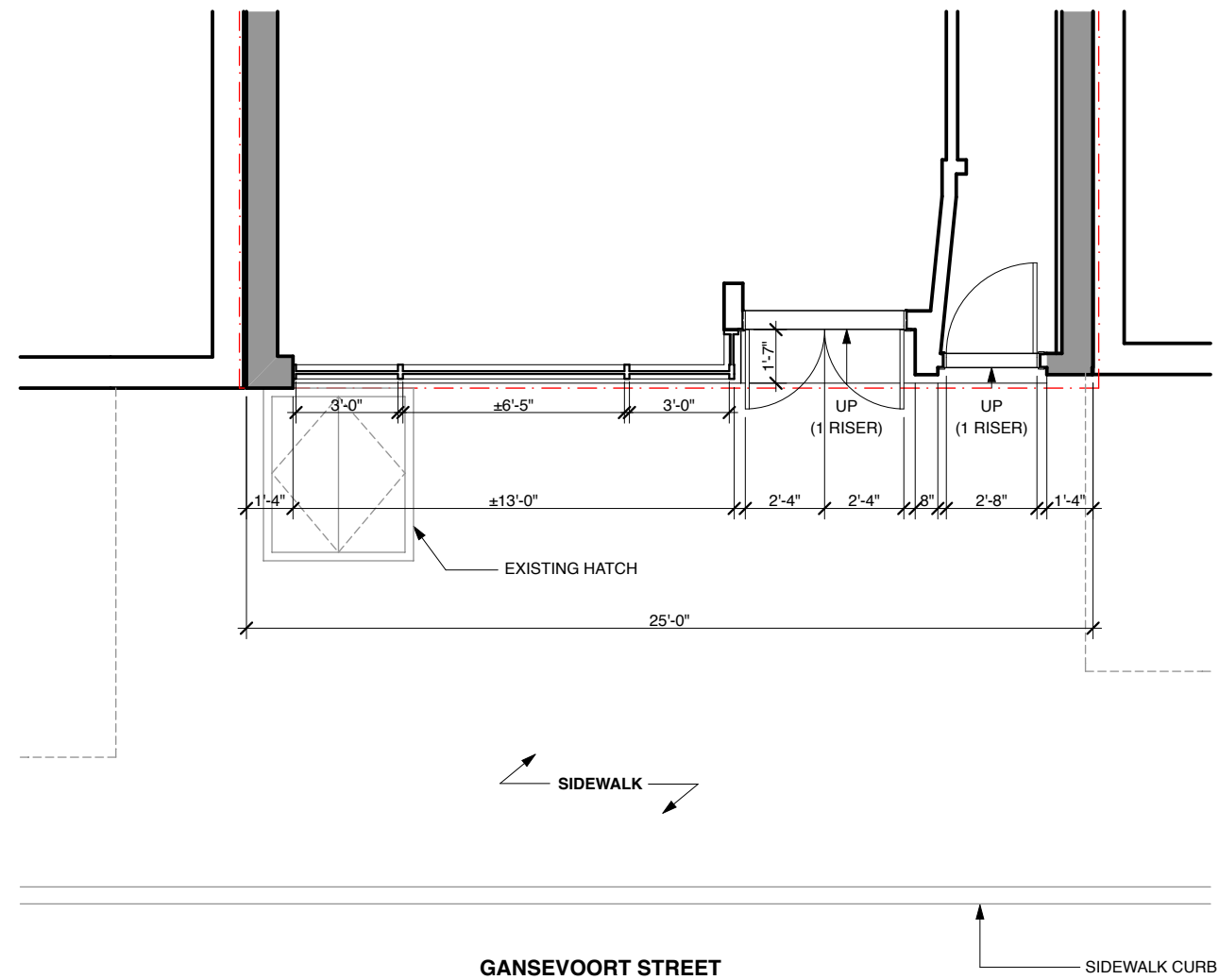

1 EXISTING STOREFRONT PLAN
SCALE: 3/16" = 1'-0"

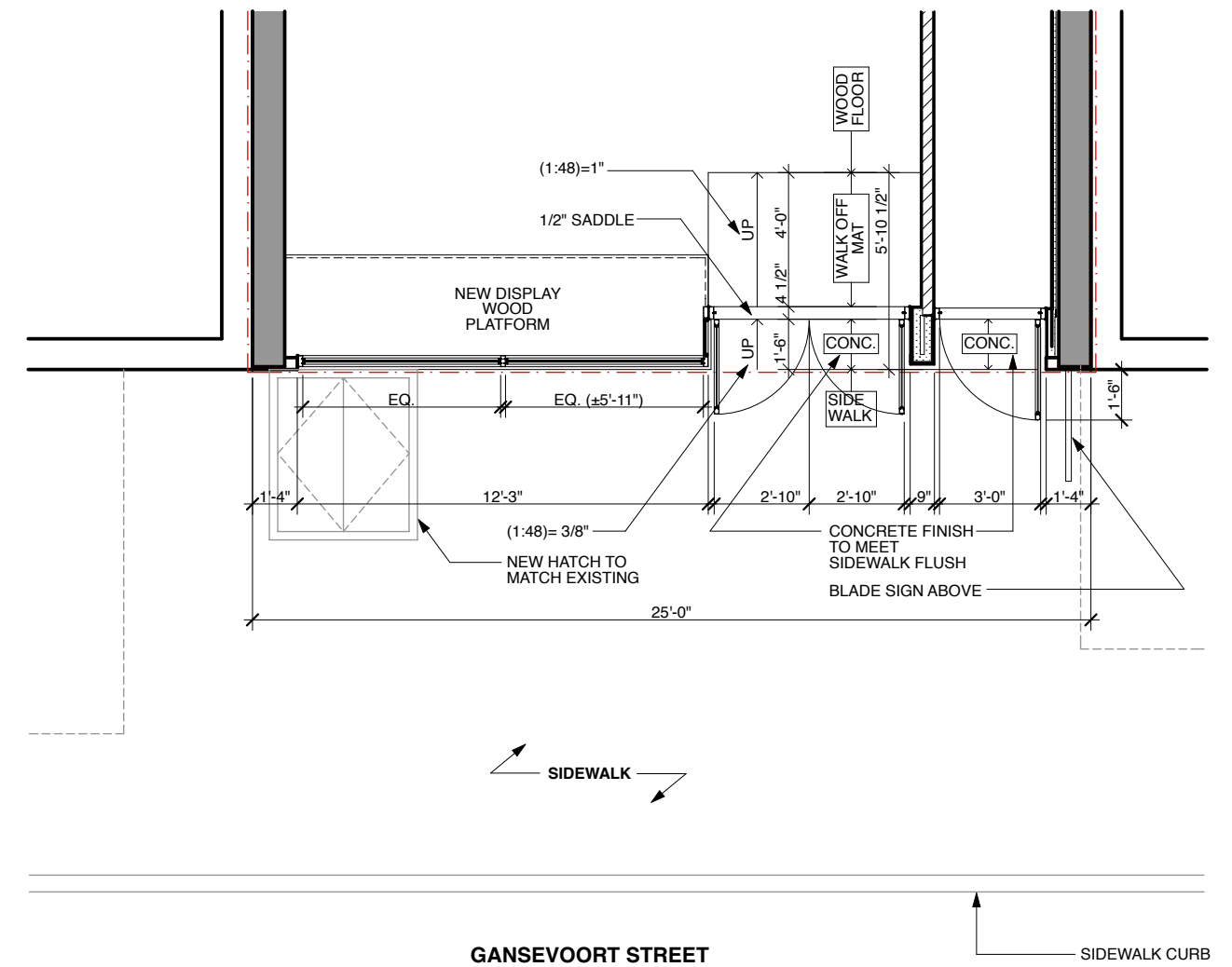

2 NEW STOREFRONT PLAN
SCALE: 3/16" = 1'-0"

NOTE:
FINISHES OF ALL NEW S.S. CLADDING & DOORS TO MATCH EXISTING'S.

FINISH SCHEDULE					
ITEM	DESIGNATION	MATERIAL	MANUFACTURER	SPECIFICATION & COLOR	REMARK
STOREFRONT	GL-1	STOREFRONT CLEAR GLASS	G.C.	5/16" LAMINATED / STARPHIRE GLASS	
	GL-2	DOOR GLASS	G.C.	1/4" TEMPERED / STARPHIRE GLASS	
	OP-1	ETCHED GLASS FILM	G.C.		APPLY ON INTERIOR SIDE OF GLAZING
	SS-1	S.S. STOREFRONT SYSTEM AND S.S. PANELS	G.C.	#4B MILL FINISH TO MATCH EXISTING STOREFRONT CLADDING PANELS	
	AF-1	AWNING FABRIC	VENDOR	SUNBRELLA, #6004 NATURAL WHITE WITH #4626 NAVY BLUE LOGO	

Lalire March Architects LLP
304 Hudson Street 6 fl
New York New York 10013
212 807 1011

LalireMarchArchitects Existing & New Storefront Plans

Madewell
69 Gansevoort Street
New York, NY 10014
11/16/16



1 EXISTING STOREFRONT ELEVATION
SCALE: 3/16" = 1'-0"

2 NEW STOREFRONT ELEVATION
SCALE: 3/16" = 1'-0"

Lalire March Architects LLP
304 Hudson Street 6 fl
New York New York 10013
212 807 1011

Madewell
69 Gansevoort Street
New York, NY 10014
11/16/16

LalireMarchArchitects Existing & New Storefront Elevs.

ALL MEASUREMENTS ARE +/- AND MUST BE FIELD VERIFIED BEFORE SIGN CAN BE MANUFACTURED

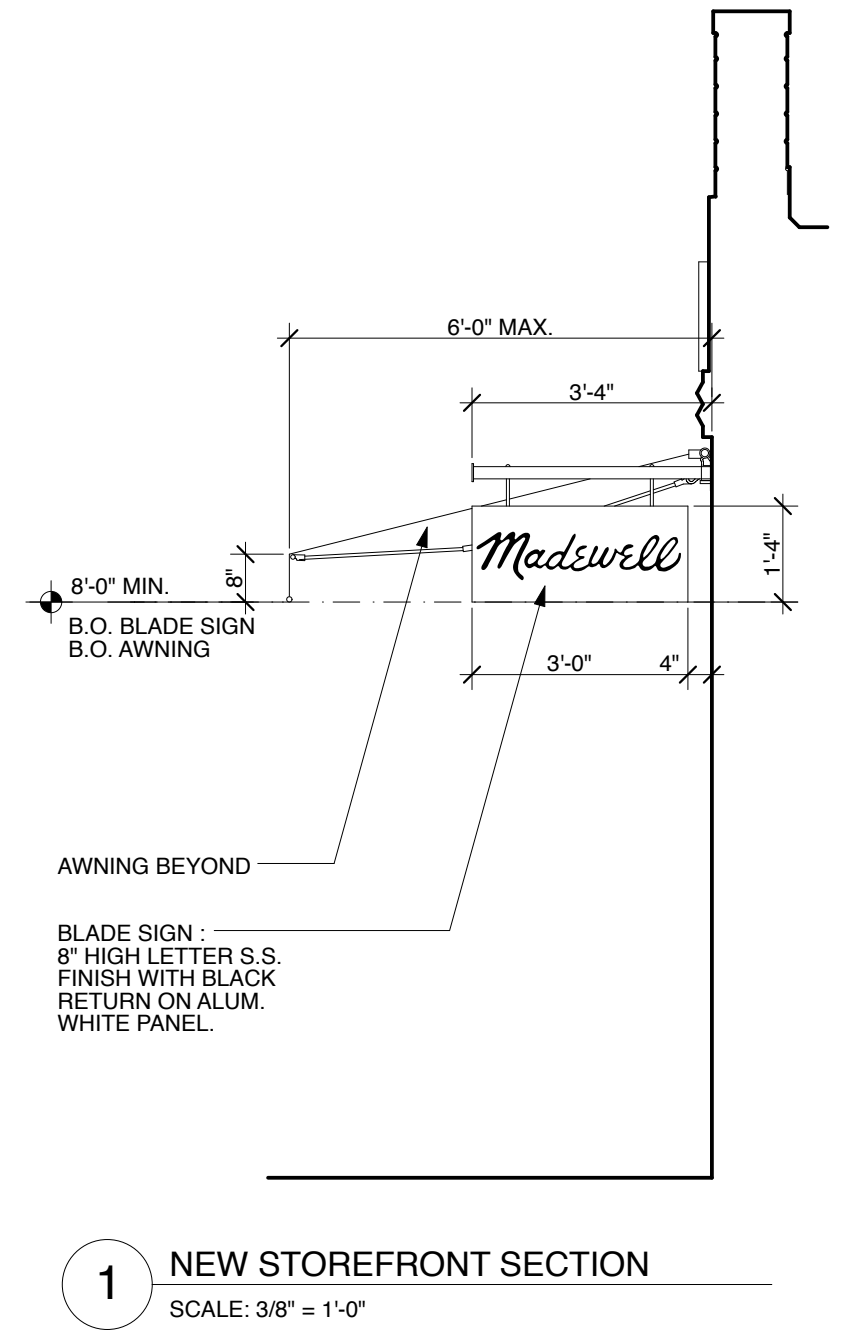
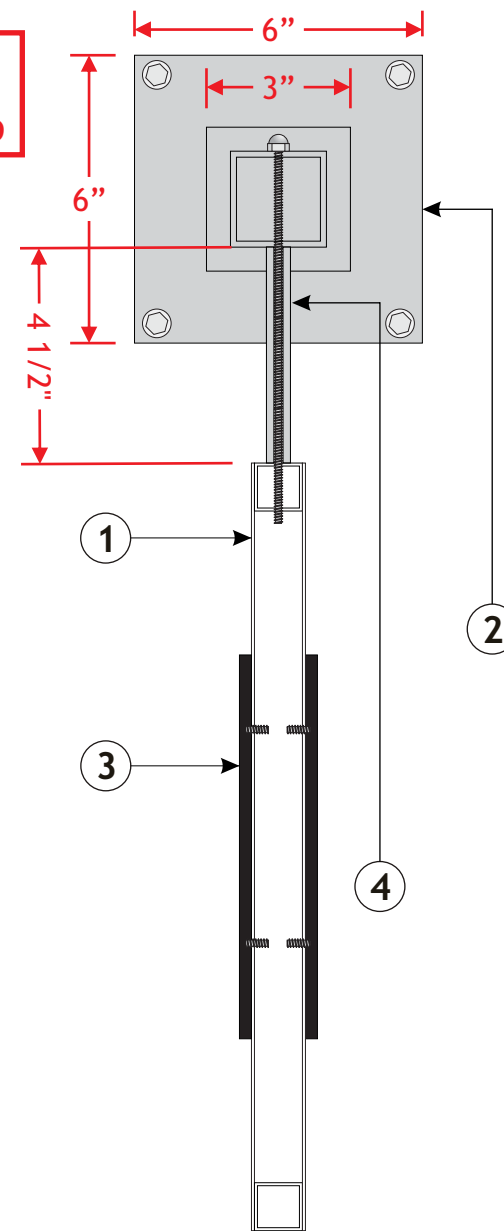
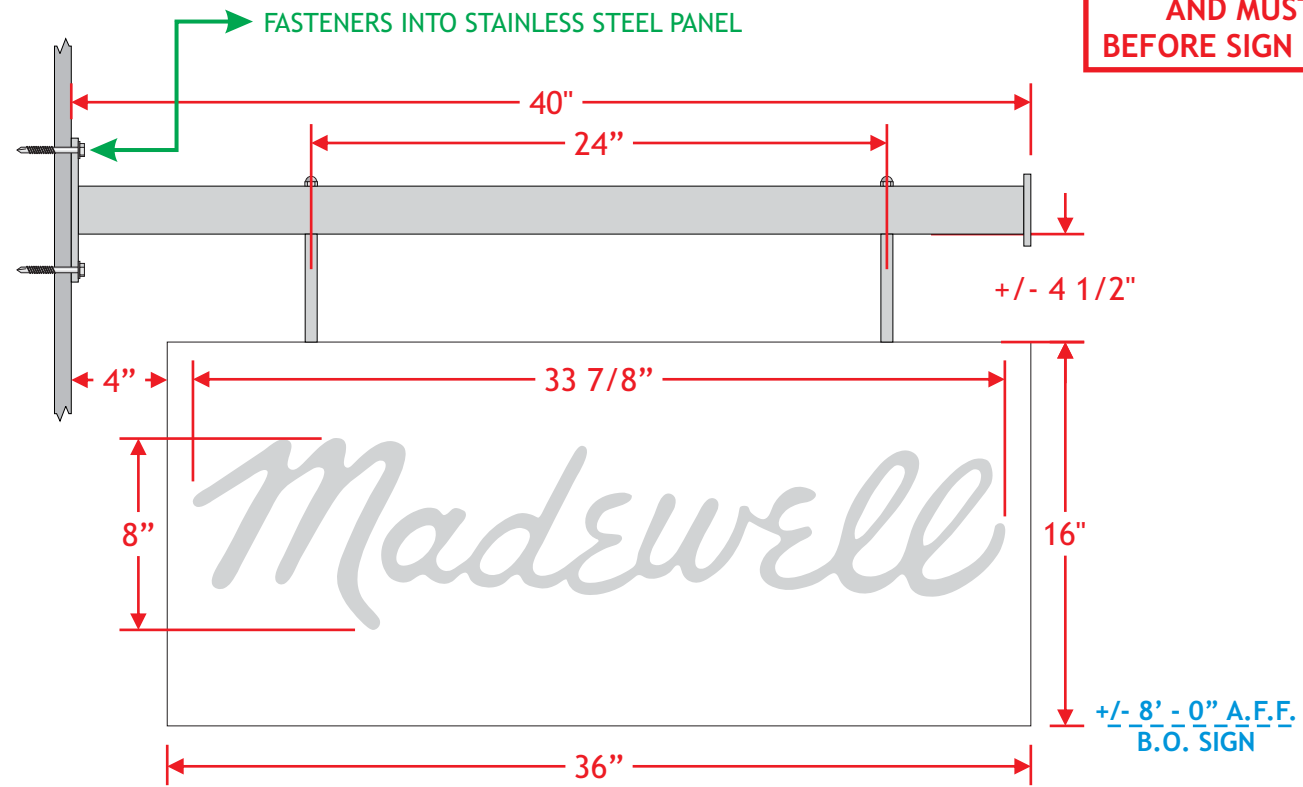

SIGN - DETAILS

- 1 16" x 36" x 1 1/8" DEEP, FABRICATED ALUMINUM SIGN BOX PAINTED MATTE WHITE
- 2 2" SQUARE STAINLESS STEEL (#4B) MOUNTING ARM WITH 6" X 1/4" THICK MOUNTING PLATE AND 3" X 1/4" END CAP
- 3 1/4" THICK STAINLESS STEEL (#4B) ROUTED COPY, BLACK RETURNS, SECURED TO BLADE SIGN WITH SILICONE AND THREADED STUDS
- 4 BLADE SUSPENDED FROM ARM WITH ALL THREAD THROUGH DECORATIVE STAINLESS SLEEVE AND ACORN NUTS
- 5 SECURED TO STOREFRONT WITH SITE SPECIFIC FASTENERS (STAINLESS) INTO BLOCKING

Lalire March Architects LLP
304 Hudson Street 6 fl
New York New York 10013
212 807 1011

LalireMarchArchitects

Madewell

69 Gansevoort Street
New York, NY 10014
11/16/16

Blade Sign



TAX PHOTO - 1940



TAX PHOTO - 1980



NEW STOREFRONT-2016

Lalire March Architects LLP
 304 Hudson Street 6 fl
 New York New York 10013
 212 807 1011

LalireMarchArchitects

Madewell

69 Gansevoort Street
 New York, NY 10014
 11/16/16

Tax Photos & New Storefront