

ZONING RESOLUTION Web Version

THE CITY OF NEW YORK



THE CITY OF NEW YORK
Bill de Blasio, Mayor

CITY PLANNING COMMISSION
Marisa Lago, Chair

Article IX: Special Purpose Districts Chapter 5: Special Transit Land Use District

Effective date of most recently amended section of Article IX Chapter 5: 11/30/17

Date of file creation: Web version of Article IX Chapter 5: 1/12/18

CITY PLANNING COMMISSION
nyc.gov/planning

DEPARTMENT OF CITY PLANNING
©Copyrighted by the City of New York

Zoning Disclaimer- the Web version of the Zoning Resolution of the City of New York is provided for reference and the convenience of having the Resolution in an online format. Recent amendments to the Zoning Resolution also appear on the Web prior to being incorporated into the print version of the Resolution.

(11/7/74)

Article IX - Special Purpose Districts

Chapter 5

Special Transit Land Use District

(11/7/74)

95-00

GENERAL PURPOSES

The "Special Transit Land Use District" established in this Resolution is designed to promote and protect public health, safety, general welfare and amenity. These general goals include the following specific purposes:

- (a) to minimize the conflict between normal pedestrian movements on public sidewalks and access to underground transit systems, by requiring developments within the Special District to provide access to underground transit or other subway amenities;
- (b) to reduce congestion on city streets in the vicinity of transportation nodes, by encouraging the provision of adequate underground pedestrian circulation systems;
- (c) to require adequate access of light and air to the subway mezzanines or station areas of the underground transit system and other related facilities in order to provide greater visibility and safety to below ground spaces;
- (d) to encourage development that reinforces and preserves the character of the existing communities within the area, by promoting needed pedestrian amenities;
- (e) to coordinate the present and future relationship of land uses within the Special District including weather protected public access to the underground transit system; and
- (f) to promote the most desirable use of land in the area and thus to conserve the value of land and buildings, and thereby protect the City's tax revenues.

(2/2/11)

95-01

Definitions

For purposes of this Chapter, matter in italics is defined in Section 12-10 (DEFINITIONS).

(2/2/11)

95-02

General Provisions

#Special Transit Land Use Districts# are mapped in the vicinity of existing or proposed subway stations. Except as modified by the express provisions of this Chapter, the regulations of the underlying district remain in effect.

Whenever this Special District overlaps another Special District and imposes contradictory regulations, the provisions of the #Special Transit Land Use District# shall apply. Nothing contained in this regulation shall be understood to supersede Landmark or Historic District designations of the New York City Landmarks Preservation Commission.

(11/30/17)

95-03

Transit Easement

Any #development# or #enlargement# involving ground level construction within the #Special Transit Land Use District# shall provide an easement on the #zoning lot# for subway-related use and public access to the subway mezzanine or station when required pursuant to the provisions of Section 95-04.

The issuance by the Department of Buildings of an excavation permit for any #zoning lot# located within the Special District shall be dependent upon prior compliance with the provisions of this Chapter.

The transit easement required on a #zoning lot# shall permit the realization of one or more of the following planning objectives:

- (a) the integration and relating of subway station design to surrounding development;
- (b) the introduction of light and air to: stations; mezzanines;

and other related facilities constructed pursuant to the provisions of Section 95-032 (Determination of transit easements at other stations);

- (c) the reduction of conflict between pedestrian movements and station facilities on the #street# level;
- (d) the provision of weather protection for subway entrances;
- (e) the relation of subway entrances to #commercial# and other transit facilities;
- (f) the provision of maximum visual exposure of subway entrances from public areas; and
- (g) the elimination or reduction of adverse environmental impact accompanying subway development.

In no event, however, may the easement area be used temporarily or permanently for any other purpose not immediately related to pedestrian amenity, except as hereinafter provided.

(11/30/17)

95-031

Selection of transit easement at certain stations

At the stations specified below, the transit easement required on a #zoning lot# shall constitute a volume whose dimensions above and below #curb level# shall comply with the requirements as set forth in Table A or Table B of this Section, depending on the depth of the proposed subway mezzanine below #curb level#, as established by the Metropolitan Transportation Authority.

Six possible types of transit easements are listed in Table A and in Table B. The applicant for a #development# or an #enlargement# involving ground level construction shall, in consultation with the Metropolitan Transportation Authority and the City Planning Commission, select the easement type that is most appropriate for the location.

TABLE A
 MINIMUM DIMENSIONS FOR TRANSIT EASEMENT VOLUME
 (in feet)

Stations: Houston St., Kips Bay, Lenox Hill and E. 96th St.

Easement Type	Height above #Curb Level# (h)	Depth below #Curb Level#* (D)	Length (L)	Width (W)	#Zoning Lots# less than 10,000 sf	#Zoning Lots# 10,000 sf or more
1	15	20	80	20	x	
2	15	30	80	20	x	x
3	15	30	85	32		x
4	15	25	80	10	x	
5	15	30	80	10	x	
6	15	25	60	20	x	

* See Section 95-054

TABLE B
 MINIMUM DIMENSIONS FOR TRANSIT EASEMENT VOLUME
 (in feet)

Stations: Chatham Square, Grand St., 14th St., 23rd St., UN Plaza, East Midtown and Yorkville

Easement Type	Height above #Curb Level# (h)	Depth below #Curb Level#* (D)	Length (L)	Width (W)	#Zoning Lots# less than 10,000 sf	#Zoning Lots# 10,000 sf or more
1	15	20	80	20	x	
2	15	40	100	20	x	x
3	15	40	85	32		x
4	15	35	100	10	x	
5	15	40	100	10	x	
6	15	35	65	20	x	

* See Section 95-054

Type 1 is appropriate on #zoning lots# of less than 10,000 square feet with adequate lot frontage and where the Metropolitan Transportation Authority provides final access to the subway mezzanine level under a public right-of-way.

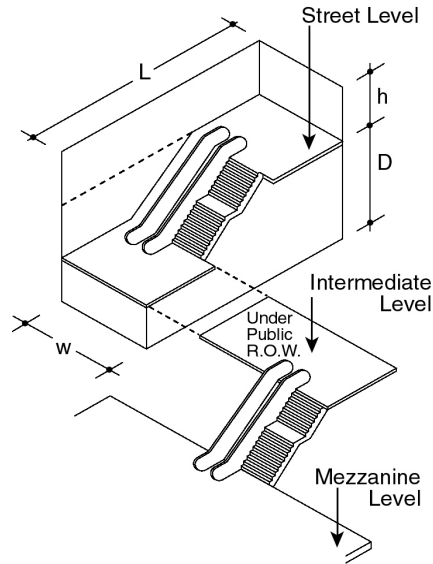

(95-031.1)

Type 2 is appropriate on any size #zoning lot# for providing direct access to the subway mezzanine level by a "straight run" stairway and/or escalator.

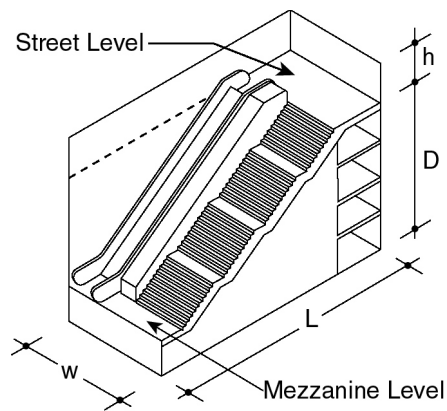

(95-031.2)

Type 3 is applicable to #zoning lots# of 10,000 square feet or more for providing a "turn around" arrangement of stairs.

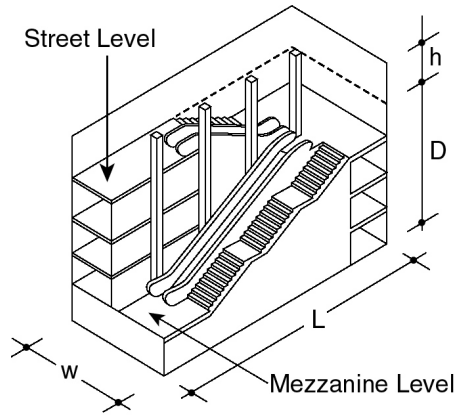

(95-031.3)

Types 4 and 5 are limited to #zoning lots# of less than 10,000 square feet with a narrow lot frontage for a single "straight-run" transit access facility, such as an escalator or stairway.

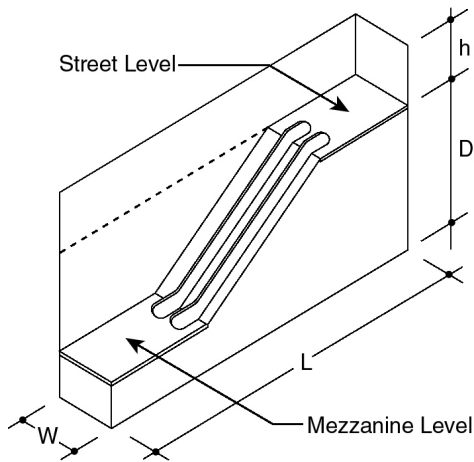

(95-031.4)

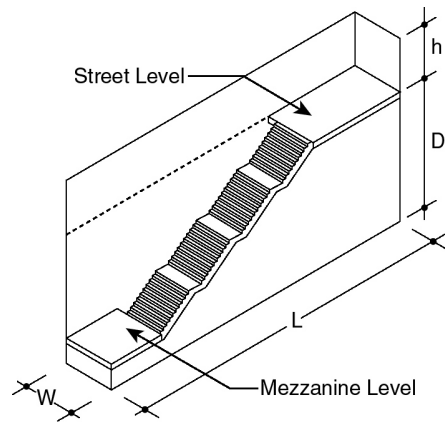

(95-031.5)

Type 6 is appropriate on #zoning lots# of less than 10,000 square feet for providing a "turn around" arrangement of stairs.

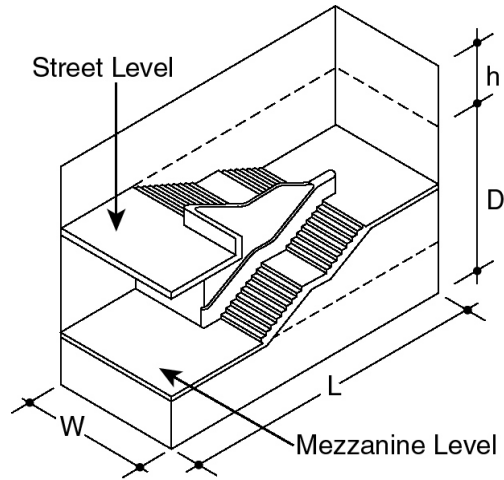

(95-031.6)

Where appropriate, any of these easement types may be used exclusively for light wells.

The Metropolitan Transportation Authority and the Commission, in consultation with the applicant, may make minor modifications of the dimensions of the easement volume type required on the applicant's site and the spacing of #building# columns permitted within the easement volume to facilitate the design and construction of circulation facilities appropriate for the area.

(11/30/17)

95-032

Determination of transit easement at other stations

At the 106th Street, 116th Street and 125th Street stations, a transit easement shall be provided to accommodate, whether singly or in any combination, light wells, stairs, ramps, escalators, elevators, passageways, or ancillary facilities required to support the functioning of subway station or rail mass transit facilities, including, but not limited to, emergency egress or ventilation structures, the Metropolitan Transportation Authority shall, in consultation with the owner of the #zoning lot# and the City Planning Commission, determine the appropriate type of transit easement and reasonable dimensions for such transit easement volume.

(11/30/17)

95-033

Location of transit easements

The transit easement volume may be located within a #building#, in open areas, including #public plazas#, or in areas covered by projected overhangs of a #building#. At least one vertical face of the easement volume shall be at a #front lot line#. The easement volume shall be located on the #zoning lot# as close as possible to the #street# containing the transit line.

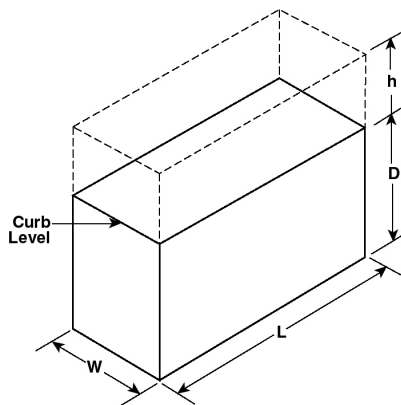

- h – Height above curb level
- D – Depth below curb level
- L – Length
- W – Width

TRANSIT EASEMENT VOLUME
(95-032)

(12/20/79)

95-04

Certification of Transit Easement Volume

(2/2/11)

95-041

For developments or enlargements

Prior to filing any applications with the Department of Buildings for an excavation permit or building permit for a #development# or #enlargement# within the #Special Transit Land Use District#, the owner of the #zoning lot# shall file an application with the Metropolitan Transportation Authority and the City Planning Commission requesting a certification as to whether or not a transit easement volume is required on the #zoning lot#.

Upon receipt of the completed application, the Commission shall furnish a copy to the affected Community Board.

Within 60 days after receipt of such application, the Metropolitan Transportation Authority and the Commission shall jointly certify whether or not an easement is required on the #zoning lot#. Failure to certify within the 60-day period will release the owner from any obligation to provide a transit easement volume on such #zoning lot#.

When the Metropolitan Transportation Authority and the Commission indicate that such easement is required, the owner shall submit a site plan indicating the location and type of easement volume that would be most compatible with the proposed #development# or #enlargement# on the #zoning lot# for joint approval and final certification by the Metropolitan Transportation Authority and the Commission. Copies of such certification shall be forwarded by the City Planning Commission to the Department of Buildings.

Use Group T #uses# shall not be permitted in #Residence Districts# prior to the improvement of a transit easement in accordance with approval and certified plans.

(2/2/11)

95-042**For substantially vacant existing zoning lots**

When a #zoning lot# located within the #Special Transit Land Use District# is substantially vacant and appropriate for a transit easement, the Metropolitan Transportation Authority may request the City Planning Commission to certify that a portion of such #zoning lot# is necessary for a transit easement.

As a condition for securing a transit easement on such #zoning lot#, the Commission shall make the following findings:

- (a) that such transit easement is required by the Metropolitan Transportation Authority to provide public access to a subway mezzanine or to a public passageway leading to a subway mezzanine or platform;
- (b) that such transit easement is located on a vacant portion of a #zoning lot#;
- (c) that the use of the transit easement will not reduce development potential on the #zoning lot# under the applicable district regulations; and
- (d) that the Metropolitan Transportation Authority and the owner agree that the construction within the easement volume will be integrated with the total development.

At such time as an existing vacant #zoning lot# on which a transit easement volume provided pursuant to the provisions of this Section, is #developed#, it shall be subject to all regulations of this Chapter.

(11/30/17)

95-05**Terms and Conditions for Permitted Uses and Construction Within Transit Easement Volume**

The transit easement volume shall be used as an entrance/exit for public access to the subway and/or to provide better access of light and air to the subway station mezzanine, and for related uses. Illustrative of such purposes are light wells, stairs, ramps, escalators, elevators or, for #zoning lots# subject to the provisions of Section 95-032 (Determination of transit easements at other stations), ancillary facilities required to support the functioning of subways, including, but not limited to, emergency egress or ventilation structures.

No #floor area# bonus shall be allowed for any transit easement provided on a #zoning lot#. When a transit easement volume required on a #zoning lot# is located within a #building#, any floor spaces occupied by such transit easement volume shall not count as #floor area#. Any portion of the #lot area# of a #zoning lot# occupied by a transit easement and weather protected by an overhang or roofed area, shall be considered as a #public plaza# in the districts that allow such #public plaza# bonuses.

The transit easement volume, any construction allowed therein or any weather protection provided thereon by an overhang or roofed area pursuant to Section 95-053, shall be considered permitted obstructions within required #yards#, #open space# or in a #public plaza# area.

(11/30/17)

95-051

Development of transit access facilities

All access facilities, including any light wells or sky lights required within a transit easement volume established pursuant to the provisions of Section 95-031 (Selection of transit easement at certain stations), or access and ancillary facilities required pursuant to the provisions of Section 95-032 (Determination of transit easement at other stations), shall be constructed and maintained by the Metropolitan Transportation Authority except for any #building# columns, footings or any other permitted obstructions allowed therein.

The subway entrance within the transit easement volume and any adjoining #public plaza# shall be at the same elevation as the adjoining sidewalk and shall be directly accessible to the public at all times. When such entrance is not located at the #street line#, it shall be visually prominent and directly accessible from a #street# by a paved pedestrian walk at least 20 feet in width and at the same elevation as the adjoining sidewalk. Such privately owned pedestrian walk shall be maintained by the owner. In order to provide natural light to the subway mezzanine level, at least 10 percent of the transit easement area at #curb level# shall be provided with light wells and skylights.

(11/30/17)

95-052

Special access facilities for persons with disabilities at certain stations

For #zoning lots# subject to the provisions of Section 95-031 (Selection of transit easement at certain stations), special elevators for persons with disabilities may locate within a transit easement volume, provided stair and/or escalator access to the subway mezzanine are located within the same easement and in no event located within the public sidewalk adjacent to the #zoning lot#.

Such special elevators shall be designed by the Metropolitan Transportation Authority in consultation with the owner of the #zoning lot# and shall be integrated architecturally, including color and material, with the #buildings# on the #zoning lot# and with adjoining #public plaza# area. Design concept for such elevators shall be submitted to the City Planning Commission for certification.

(2/2/11)

95-053

Weather protection

The stairs or escalators providing pedestrian access to the subway mezzanine, which are not covered at the entrance level, shall be weather protected by the #building# or portion thereof including an overhang, or by a roofed area provided by the owner of the #zoning lot# in accordance with the Metropolitan Transportation Authority requirements. Such overhang or roofed area shall cover either or both the stairway and the escalator which are uncovered at the ground level. Any overhang or roofed area shall be sufficient to cover the access facilities within the easement volume and may not otherwise obstruct the #public plaza#.

When the subway entrance is within an open #public plaza# area, a roof area shall be provided with either a glazed or translucent material for at least 50 percent of its surface area. The roofed area shall be no more than 15 feet above #curb level# and shall blend harmoniously with the #buildings# on the #zoning lot# and any adjoining #public plaza# or open area.

(2/2/11)

95-054

Permitted uses and other constructions

Areas within the easement volume not used for circulation purposes may be developed only with newsstands, cigar stands, flower stands or similar stands, in accordance with the Metropolitan Transportation Authority specifications, provided they do not interfere with pedestrian circulation and are made of removable structures. In no event shall such permitted #uses# be located within 10 feet of a pedestrian entrance to the subway at #curb level#.

In addition, any portion of the transit easement volume at #curb level# not to be covered for weather protection, may contain trees, benches or any obstructions permitted in a #public plaza# area. However, such elements shall not interfere with the pedestrian movement.

The Metropolitan Transportation Authority and the City Planning Commission may permit penetration of the transit easement volume above #curb level# by a #building# lobby, including #building# columns, where such lobby space serves as a part of the pedestrian circulation system and provides from it direct public access to the subway entrance within the easement volume.

Where construction within a transit easement volume is more than five feet in height above #curb level#, such construction proposal shall be submitted to the Commission for a review and certification to ensure that such construction relates harmoniously to the total development. When a transit easement volume is located within a #building#, it shall be open to the general public for the same hours of operation as the subway station.

#Building# columns or footings are permitted inside the transit easement volume, provided that the minimum clear distance between any columns is 12 feet and between the columns and any bounding walls of the transit easement volume is 10 feet. Where the width of an easement is greater than 20 feet, location of columns within the easement volume shall be established in consultation with the Metropolitan Transportation Authority. In all cases, the depth of columns or footings within the easement area or adjoining area shall be established in consultation with the Metropolitan Transportation Authority. Furthermore, vertical space between such columns shall be open and unobstructed from its base except for any construction permitted under the provisions of this Chapter.

95-055

Knockout panel

Any underground walls constructed along the #front lot line# of a #zoning lot# in which transit easement volume is required by the Metropolitan Transportation Authority shall contain a knockout panel, not less than 12 feet wide, below #curb level# down to the bottom of the easement. The actual location and size of such knockout panel shall be indicated by the Metropolitan Transportation Authority.

(2/2/11)

95-06

Temporary Use of the Easement Area

Any easement volume required on a #zoning lot# pursuant to the provisions of this Chapter may be temporarily used by the owner of the #zoning lot# for any permitted #uses# until such time as required by the Metropolitan Transportation Authority or by its designee for subway purposes.

Temporary #use# of the transit easement volume above #curb level# in a #public plaza# or #open space# area shall be limited to #use# as a landscaped open area that may contain obstructions permitted in a #public plaza#. Improvements or construction of a temporary nature within the easement volume for such temporary #uses# shall be removed by the owner of the #zoning lot# prior to the time at which public #use# of the easement area is required. A minimum notice of six months in writing shall be given by the Metropolitan Transportation Authority to the owner of the #zoning lot# in order to vacate the tenants of such temporary #uses#.

(2/2/11)

95-07

Special Provisions for an Increase in Zoning Tower Coverage on Zoning Lots Containing Transit Easements

For any #zoning lot# on which a transit easement volume is required pursuant to Section 95-04, the #lot coverage# of a tower permitted by the underlying district regulations may be increased by an amount equal to 10 percent of the #lot area# of the #zoning lot#.

In no event shall the permitted increase in tower coverage on a #zoning lot# affect the maximum allowable #floor area ratio# under the applicable district regulations.

(2/2/11)

95-08

Special Use Regulations

In order to promote the continued development of retail and related #uses# which are most appropriate for pedestrians using transit facilities, the only #commercial uses# permitted in the subway mezzanine level, along with the bounding walls of the transit easement volume and at the ground #story# of any #development# or #enlargement# within the Special District, shall be those #uses# listed in Use Group T in Section 95-081.

Use Group T #uses# shall not be permitted in #Residence Districts# prior to the improvement of a transit easement in accordance with approved and certified plans.

In all underlying districts within the Special District, below the lowest #story# occupied by #residential uses#, Use Group T #uses# are permitted to occupy no more than two #stories# above #curb level#. However, #uses# listed in paragraphs A, C or E of Section 95-081 are permitted within the Special District only where allowed by the underlying district regulations. Location of #commercial uses# within a #building# shall be governed by the provisions of Section 32-42.

In the subway mezzanine, at ground #story# and along the bounding walls of the transit easement volume, the frontage occupied by any #uses# shall not exceed 25 linear feet per establishment within a distance of 75 feet from the edge of the easement volume at any level.

(2/8/90)

95-081

Use Group T

Use Group T comprises a group of retail establishments selected to promote and strengthen retail business in the Special District. #Uses# marked with an asterisk (*) shall not be located at the subway mezzanine level or along the bounding walls of a transit easement volume.

A. Amusements

Billiard parlors or pool halls

Model car hobby centers, including racing

Theaters

B. Convenience Retail or Service Establishments

Bakeries, provided that no floor space is used for production

Barber shops

Beauty parlors

Drug stores

*Dry cleaning or clothes pressing establishments or receiving stations dealing directly with ultimate consumers, limited to 2,000 square feet of #floor area# per establishment, and provided that only solvents with a flash point of not less than 138.2 degrees Fahrenheit shall be used, and total aggregate dry load capacity of machines shall not exceed 60 pounds

Eating or drinking establishments, including those which provide outdoor table service or have music for which there is no cover charge and no specified showtime

Eating or drinking establishments, with musical entertainment, but not dancing, with a capacity of 200 persons or fewer

*Food stores, including grocery stores or delicatessen stores

*Fruit stands, including supermarkets or meat markets

Hardware stores

*Laundry establishments, hand or automatic self-service

*Package liquor stores

Post offices

Shoe or hat repair shops

Stationery stores

Tailor or dressmaking shops, custom

Variety stores, limited to 10,000 square feet of #floor
area# per establishment

C. Offices

*Offices, business, professional or governmental

D. Retail or Service Establishments

Antique stores

Art galleries, commercial

Artists' supply stores

Banks

Bicycle sales

*Blueprinting or photostatting establishments

Book stores

*Business schools or colleges

Candy stores or nut stores

*Carpet, rug, linoleum or other floor covering stores

Cigar or tobacco stores

Clothing or accessory stores

Clothing or costume rental establishments

Dry goods or fabric stores

Electrolysis studios

Fishing tackle or equipment, rental or sales

Florist shops

Furniture stores

Furrier shops, custom

Gift shops

**Gymnasiums, used exclusively for basketball, handball, squash and tennis

*Ice cream stores

Interior decorating establishments, provided that #floor area# used for processing, servicing or repairs shall be limited to 750 square feet per establishment

Jewelry or art metal craft shops

Leather goods or luggage stores

Loan offices

Locksmith shops

*Medical or orthopedic appliance stores

*Meeting halls

Millinery shops

Music stores

Musical instrument repair shops

Newsstands, open or enclosed

Optician or optometrist establishments

*Paint stores

*Pet shops

Photographic equipment or supply stores

Photographic studios

** #Physical culture or health establishments#, including gymnasiums (not listed under Use Group 9), reducing salons, massage establishments or steambaths, but other than #adult physical culture establishments#

Picture framing shops

Record stores

Seed or garden supply stores

Sewing machine stores, selling household machines only

Shoe stores

Sporting or athletic stores

Stamp or coin stores

Studios, art, music, dancing or theatrical

Telegraph offices

* Television, radio, phonograph or household appliance repair stores

Television, radio, phonograph or household appliance shops

Toy stores

Travel bureaus

Typewriter or other small business machine repair shops

Typewriter stores

Umbrella repair shops

Wallpaper stores

Watch or clock stores or repair shops

E. Other Retail or Wholesale Establishments

Department stores

*Hair products for headwear, wholesaling, including styling

*Medical or dental laboratories for research or testing, or the custom manufacture of artificial teeth, dentures or plates, not involving any danger of fire or explosion nor offensive noise, vibration, smoke or other particulate matter, odorous matter, heat, humidity, glare or other objectionable effects

*Photographic developing or printing establishments, limited to 2,500 square feet of #floor area# per establishment

Plumbing, heating or ventilating equipment showrooms,
without repair facilities

F. Clubs

All types of clubs, without restrictions on activities or
facilities

G. #Accessory uses#

**#Uses# in Use Group T marked with a double asterisk are
permitted only by special permit of the Board of Standards
and Appeals, pursuant to the provisions of Section 73-36

(5/8/13)

95-09

**Special Regulations for Accessory Off-street Parking and Curb
Cuts**

Within the portion of the #Special Transit Land Use District#
located within the #Manhattan Core#, the provisions of Article I,
Chapter 3 (Comprehensive Off-street Parking and Loading
Regulations in the Manhattan Core), inclusive, shall apply. For
all other portions of the #Special Transit Land Use District#,
the provisions of this Section shall apply.

On any #zoning lot# on which a transit easement volume is
provided, the required #accessory# off-street parking
requirements for #residential uses# of the applicable underlying
districts shall be reduced to a maximum of 20 percent.

In no case within the Special District shall curb cuts for
vehicular access be located on a #street# containing transit
lines or on a #street# within 50 feet of its intersection with
the #street lines# of such a #street#.

The #accessory# parking requirements shall not apply to any
#development# or #enlargement# for which the Commissioner of
Buildings has certified that there is no way to provide the
required parking spaces with access to a #street# in conformity
with the provisions of this Section.

(4/30/08)

95-10

MISCELLANEOUS PROVISIONS

The pavement on a public sidewalk fronting a #development# within the #Special Transit Land Use District# shall be consistent in color and material with all pavements located within the transit easement volume and in any adjoining #public plaza#.

(4/30/08)

95-11

Recordation

The instrument creating a transit easement volume shall be recorded in the place and county designated by law for the filing of deeds and restrictions on real property, a certified copy of which shall be submitted to the City Planning Commission.

(2/2/11)

95-12

Termination of Transit Easement Volume

In the event that the Metropolitan Transportation Authority and the City Planning Commission jointly notify the Department of Buildings and the owner in writing that a transit easement volume is not required on a #zoning lot# in its final construction plans, the restrictions imposed on such #zoning lot# by the provisions of this Chapter shall lapse, following receipt of notification thereof by the owner, and the owner shall have the right to record an instrument reciting the consent of the Metropolitan Transportation Authority to the extinguishment of the easement volume. On any #zoning lot# which has been #developed# or upon which a #building# is #enlarged# in accordance with the provisions of Section 95-07 and on which termination of transit easement has been certified, pursuant to this Section, any open, enclosed or arcaded area reserved for transit easement at #curb level# shall be provided for public use with lighting, landscaping, trees, substantial artwork and sitting facilities.

(2/2/11)

95-13

Previous Transit Easement Agreements

Whenever, under prior zoning regulations, the owner of a #development# or #enlargement# has agreed to provide a transit easement volume on a #zoning lot#, the existence of such agreement shall be certified by the Chairperson of the City Planning Commission to the Department of Buildings. Such agreement shall be deemed to satisfy the provisions of this Chapter.